

**DIESEL ENGINE DRIVEN
STATIONARY AIR COMPRESSOR
DR750-10**

SPECIFICATIONS

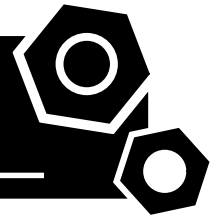

1 Standards & Conditions

Design Standards

The designs and the productions are in conformity with:

- JB/T6430-2002
- JB/T3771-2008
- JB/T4223-2007
- GB/T15487-1995
- ISO 1217-2009
- ISO 2151-2004
- ASME B 19.1-1995

Environmental Operating Conditions

- Installation place: Outdoors or indoors (well ventilated).
- Ambient temperature: -25°C to 50°C. The coolant heater is needed when the temperature is below 5°C
- Humidity: Less than 80%.
- Altitude: Below one thousand (1000) meters.

Factory Inspection

- Inspection items.
- Protection devices working test.
- Starting ability in normal temperature.
- 2 hours performance test of continuous full load.
- Performance test, including flux, pressure, temperature, noise, thermal balance etc.

Painting Process

- Painting process specifications and colors are based on the manufacturer's standard.
- The customer could also choose the color which the manufacturer offers.

2 General Features

- Cummins diesel engine
- Oil-injection double-screw air compressor
- PLC controller with microprocessor technique
- Suction valve
- Solenoid valve
- Pressure regular valve
- Safety valve
- Minimum pressure valve
- Vent valve
- Shuttle valve
- Oil thermostatic valve

- 50°C radiator
- Lubricating oil radiator
- Double layer air filter of engine
- Double layer air filter of compressor
- Lubricating oil filter
- Vertical air/oil tank (ASME approval)
- Air/oil separator
- Emergency stop button
- Lockable battery isolator switch
- 2x12V/120AH sealed for life maintenance free battery
- Fuel tank for 11 hours running
- Powder coated canopy

3 Equipment Specification

Air Compressor

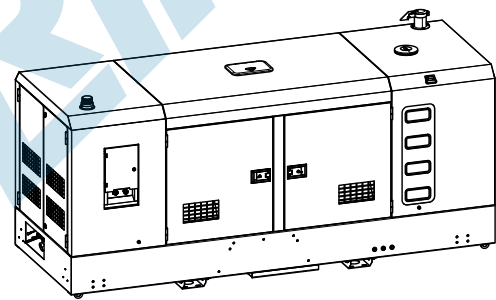

3000020738-AP1-A6

Model.....	DR750-10
Drive type	Diesel engine driven
Speed under full load.....	1850rpm
Rated flux	760cfm(21.5m ³ /min)
Rated discharge pressure	10.0bar
Max. unloading pressure	10.0bar
Min. working pressure	5.0bar
Discharge port	2xG3/4"+1xG2x11"
Total capacity of oil system.....	70L
Lubricating oil type.....	Synthetic oil
Total capacity of coolant system.....	30L
Fuel tank capacity.....	450L
Dry weight.....	3205kg
Dimensions L×W×H.....	3900x1430x1850mm

Note: all pressures in the manual are relative values (compared with atmospheric pressure)

Dck Yf GrghYa

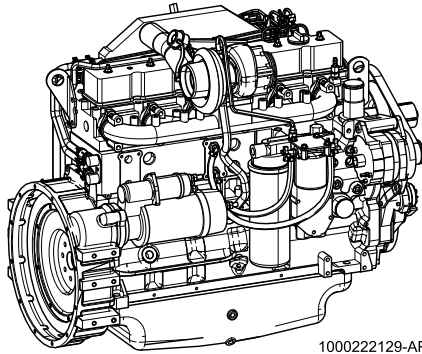

1000222129-AP1-A1

Engine Manufacturer/Brand.....	Cummins
Engine Model.....	6CTA8.3-C260
Dimensions L×W×H.....	1206x780x1014mm
Dry Weight (approx.)	627Kg
Number of Cylinders.....	6
Bore.....	114mm
Stroke.....	135mm
Displacement.....	8.3L
Compression Ratio.....	N/A
Type of injection.....	Direct injection
Intake System.....	Turbocharged
Intake Resistance.....	N/A
Cooling System.....	Water cooled
Fan.....	Pusher
Battery Voltage.....	24V
Type of Fuel.....	No.2-ASTM D975
Type of Oil.....	API CD/SE or CCMCD4
Oil Capacity.....	18L
Type of Coolant.....	Glycol mixture
Coolant Capacity.....	9.8L
Back Pressure.....	≤10.1kPa
Standby Power.....	N/A
Prime Power.....	178kW
Fuel Consumption(100%load).....	215g/kW.h

.....

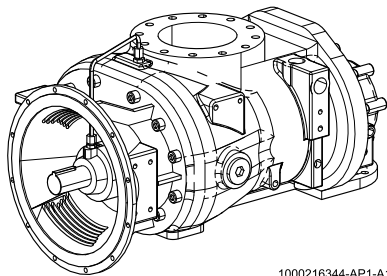

1000216344-AP1-A1

Structure.....	Oil-injection double-screw
Suction temperature.....	0-40°C

Working pressure.....	≤10.0bar
Rated speed.....	2200rpm
Weight.....	564.3kg

Control Cabinet

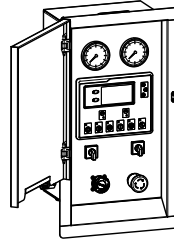

1000138882-AP1-C2

PLC of the machine is an advanced control module based on microprocessor for the automatic control and monitor system of the air compressor, realizing auto start/stop, data measure and alarm protection function. During running the module can accurately measure various parameters, like engine oil pressure, coolant temperature, discharge temperature and pressure etc. and display real values on LCD. When there is any fault, the control module alarms or stops the engine automatically and displays alarm information on LCD.

- Microprocessor control, with high stability and credibility
- Monitoring and measuring operational parameters of the air compressor
- Indicating operation status, fault conditions, all parameters and alarms
- Multiple protections; multiple parameters display, like engine oil pressure, discharge temperature and pressure etc.
- Manual and remote work mode selectable
- Real time clock for time and date display, overall runtime display
- Many configurable parameters from control panel

Warning Item	Shutdown Item
High discharge temperature	Emergency stop
High discharge pressure	Failure to start
High coolant temperature	High discharge temperature
Low engine oil pressure	High discharge pressure
Low fuel level	High coolant temperature
Low coolant level	Low engine oil pressure
Ail filter clogged	Low fuel level
Failure to stop	Low coolant level
Battery charge failure	Ail filter clogged
Low battery voltage	
High battery voltage	

4 Air and Oil Path System

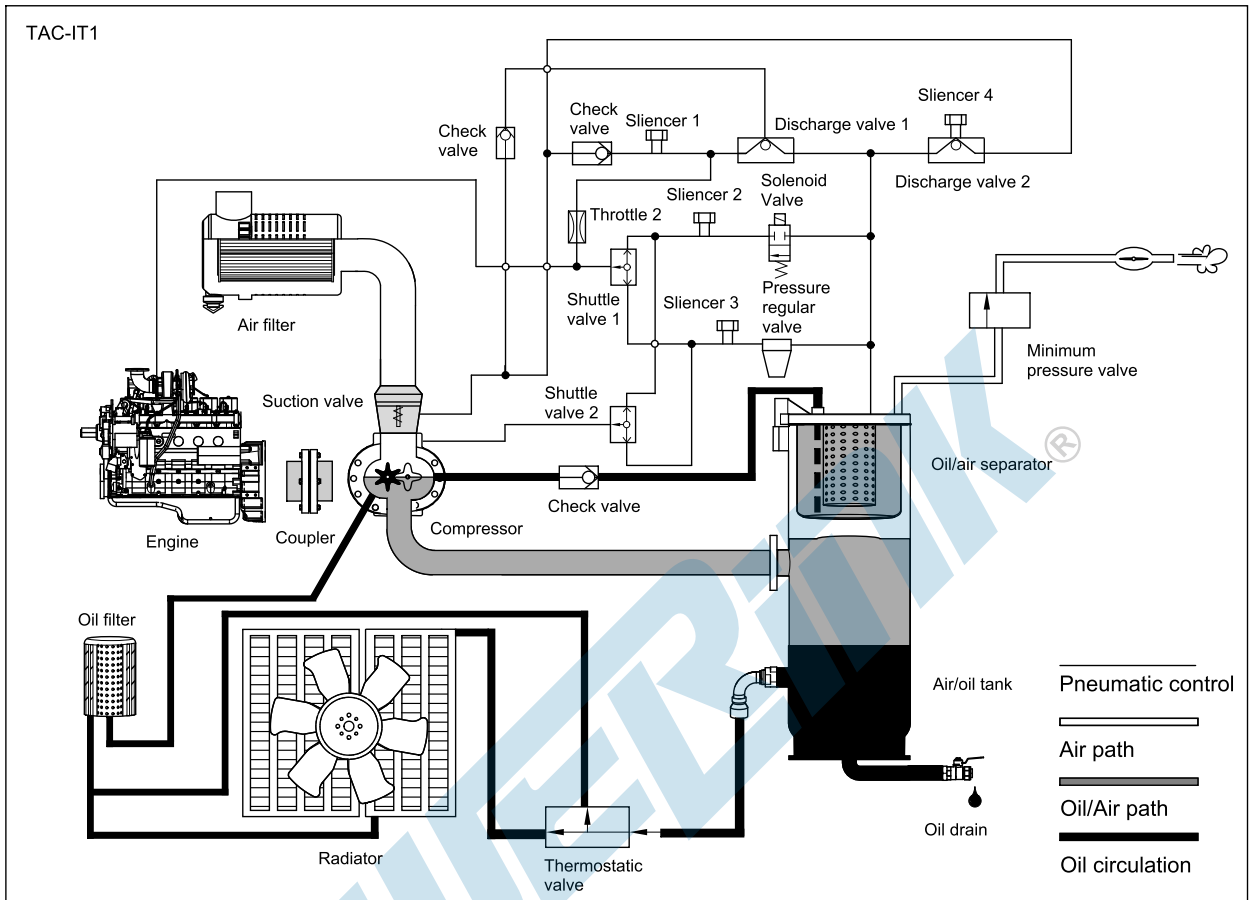

- Suction Valve
Control mode Direct proportion
Working pressure ≤ 10.0 bar
- Pressure Regular Valve
Working pressure 10.0bar
Pressure setting mode Manual
- Minimum Pressure Valve
Activation pressure 5.0bar
Fully opened pressure 5.0-5.5bar
- Thermostatic Valve
Activation temperature 85°C
Fully opened temperature 100°C
- Air/oil Tank
Working pressure ≤ 10.0 bar
Activation pressure of safety valve 11.0bar
- Air/oil Separator
Working pressure ≤ 10.0 bar
Oil residue ratio (approx.) ≤ 3 ppm

5 Control System

Control Cabinet

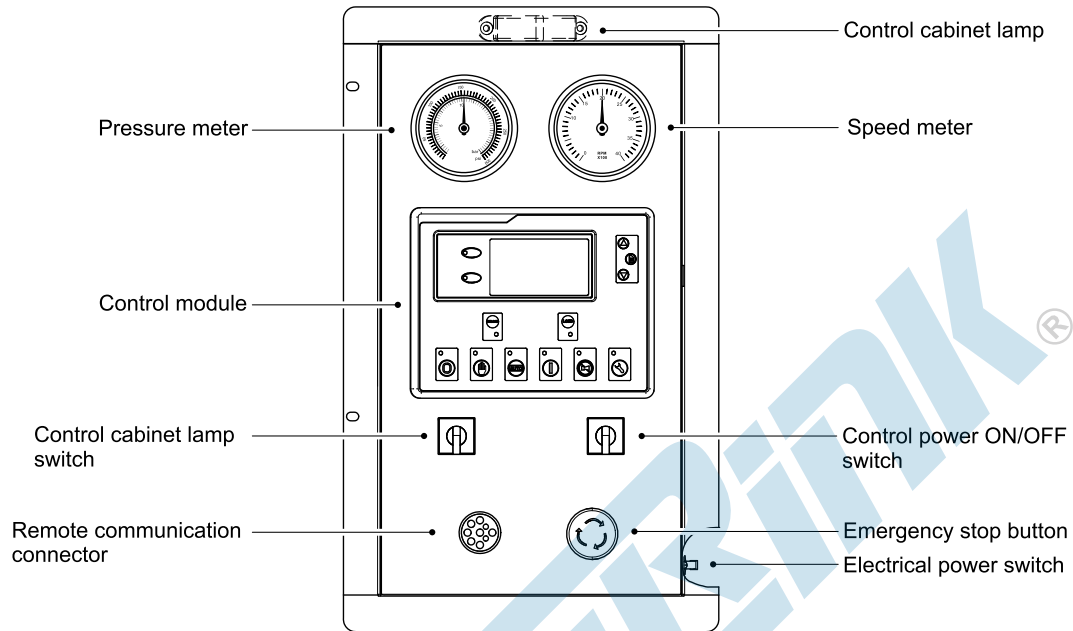

Control Module

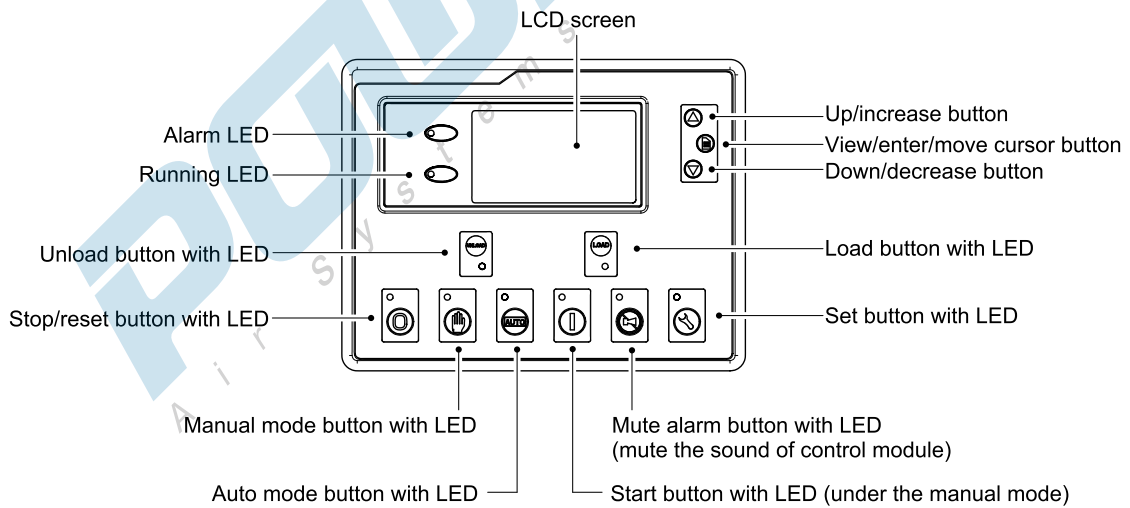

6 Overall Dimensions

3000020738-DR2-A6

Dry weight	3205kg
Dimensions	3900x1430x1850mm

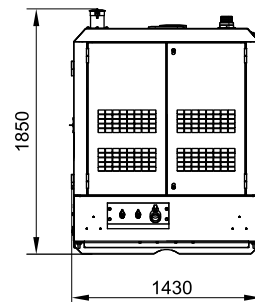
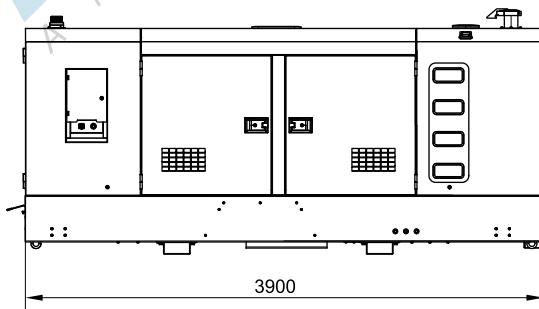
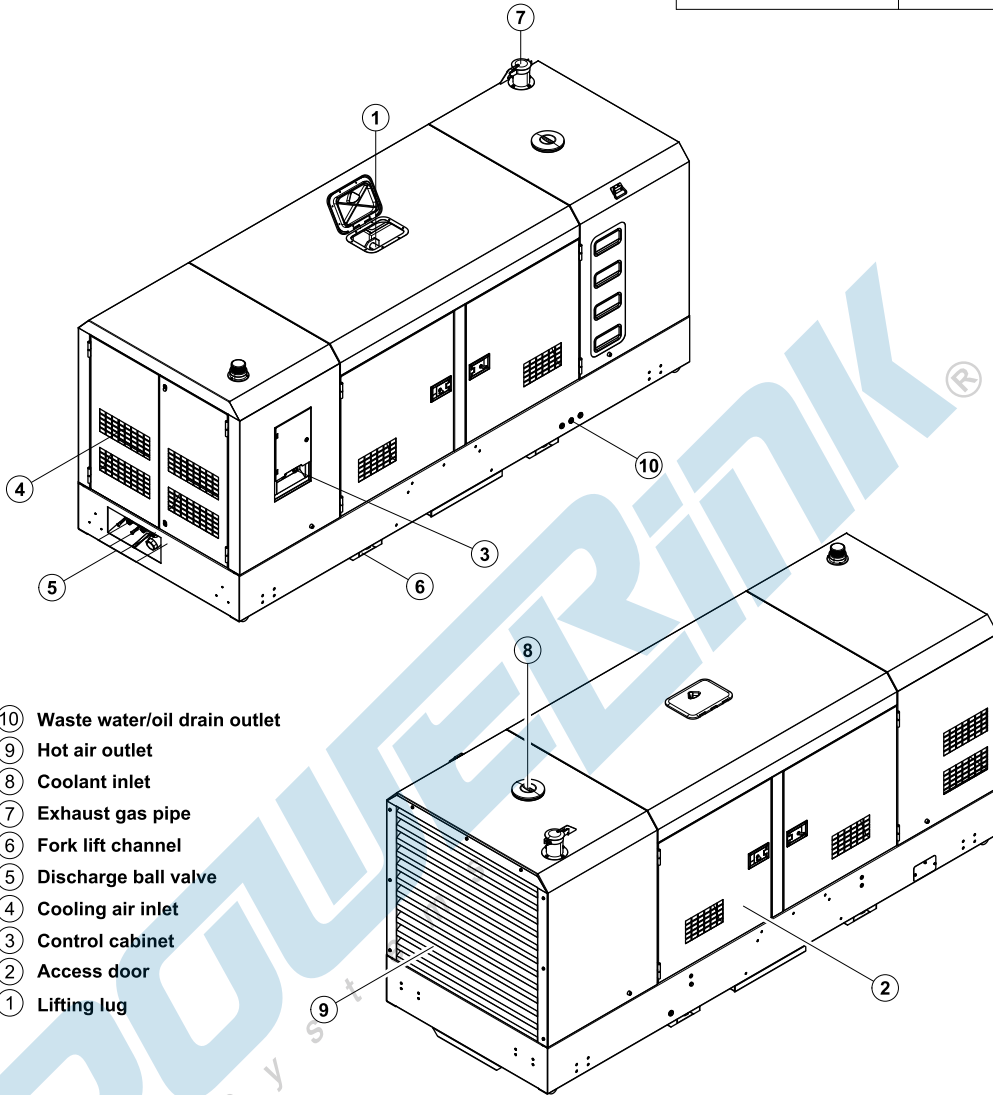

7 Optional Trailer

3000020738-DR3-A6

STANDARD TRAILER

Dry weight of the whole	3585kg
Towing speed	≤ 20km/h
Tyre size	195R14(8PR)
Dimensions of the whole	5502x2069x2363mm

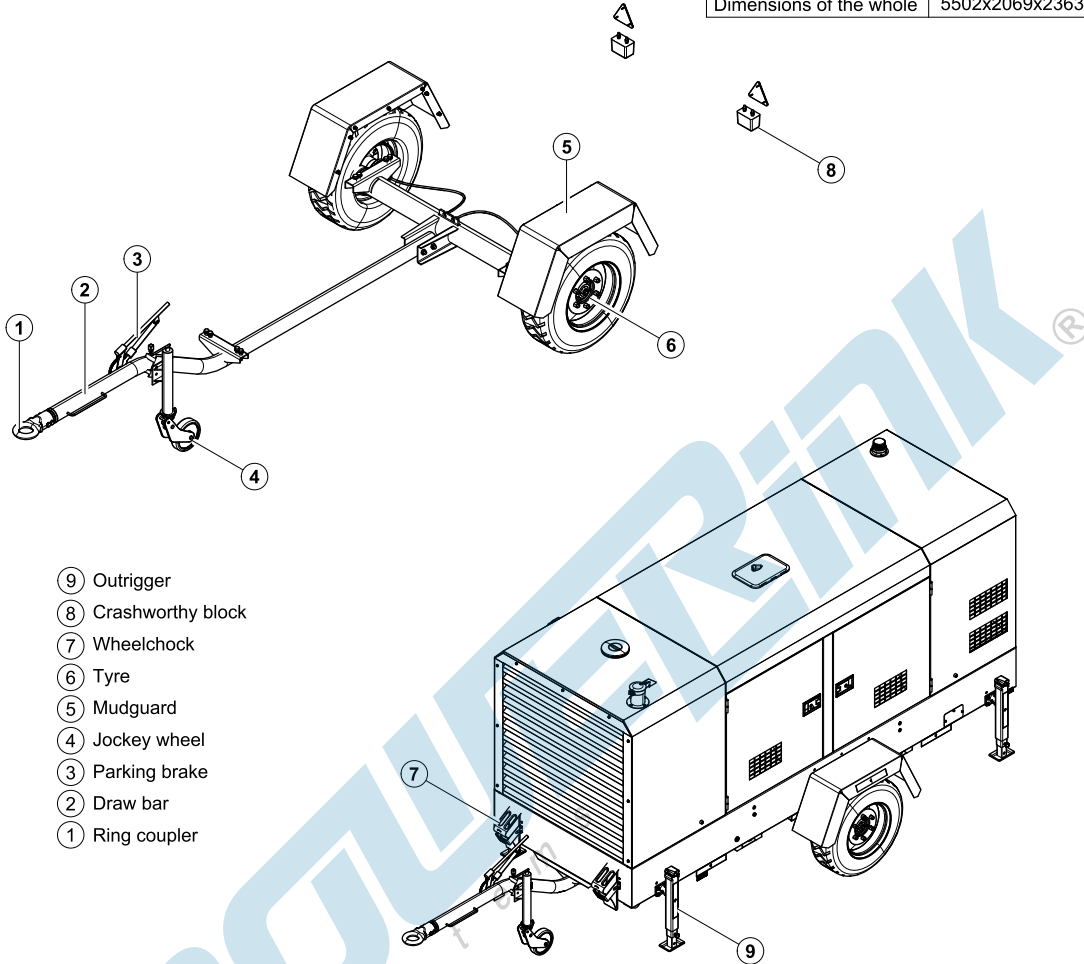

- ⑨ Outrigger
- ⑧ Crashworthy block
- ⑦ Wheelchock
- ⑥ Tyre
- ⑤ Mudguard
- ④ Jockey wheel
- ③ Parking brake
- ② Draw bar
- ① Ring coupler

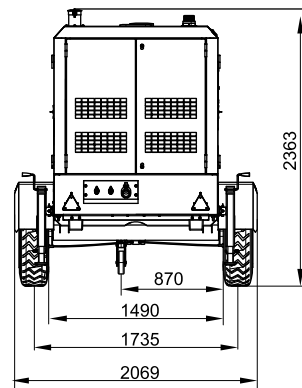
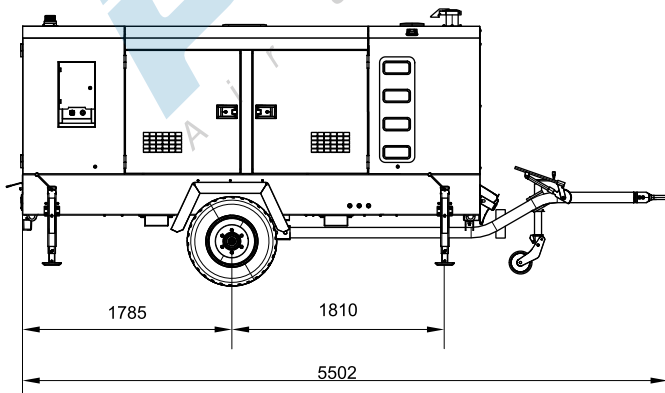

3000020738-A6-E
04.2014

POWERLINK[®]
Air Systems

<http://www.powerlinkworld.com>

*Specification may change without prior notice. For more info.,
contact Power Link or your local distributors please.*