

**DIESEL ENGINE DRIVEN
STATIONARY AIR COMPRESSOR
DR700-10**

SPECIFICATIONS

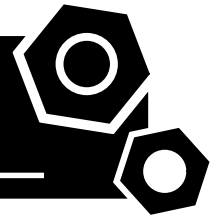

1 Standards & Conditions

Design Standards

The designs and the productions are in conformity with:

- JB/T6430-2002
- JB/T3771-1992
- JB/T4223-2007
- GB/T15487
- ISO 1217
- ISO 2151
- ASME B 19.1-1990

Environmental Operating Conditions

- Installation place: Outdoors or indoors (well ventilated).
- Ambient temperature: -25°C to 50°C. The coolant heater is needed when the temperature is below 5°C
- Humidity: Less than 80%.
- Altitude: Below one thousand (1000) meters.

Factory Inspection

- Inspection items.
- Protection devices working test.
- Starting ability in normal temperature.
- 2 hours performance test of continuous full load.
- Performance test, including flux, pressure, temperature, noise, thermal balance etc.

Painting Process

- Painting process specifications and colors are based on the manufacturer's standard.
- The customer could also choose the color which the manufacturer offers.

2 General Features

- Cummins diesel engine
- Oil-injection double-screw air compressor
- PLC controller with microprocessor technique
- Suction valve
- Solenoid valve
- Pressure regular valve
- Safety valve
- Minimum pressure valve
- Vent valve
- Shuttle valve
- Oil thermostatic valve

- 50°C radiator
- Lubricating oil radiator
- Double layer air filter of engine
- Double layer air filter of compressor
- Lubricating oil filter
- Vertical air/oil tank (ASME approval)
- Air/oil separator
- Emergency stop button
- Lockable battery isolator switch
- 2x12V/120AH sealed for life maintenance free battery
- Fuel tank for 11 hours running
- Powder coated canopy

3 Equipment Specification

Air Compressor

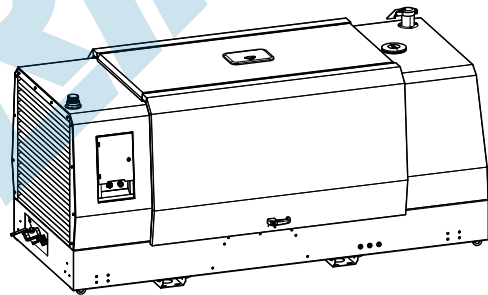

3000020038-AP1-F3

Model.....	DR700-10
Drive type	Diesel engine driven
Speed under full load.....	2200rpm
Rated flux	700cfm(19.8m ³ /min)
Rated discharge pressure	10.0bar
Max. unloading pressure	10.0bar
Min. working pressure	5.0bar
Discharge port	3xG3/4"+1xG1 1/2"
Total capacity of oil system.....	60L
Lubricating oil type.....	Synthetic oil
Total capacity of coolant system.....	30L
Fuel tank capacity.....	450L
Dry weight.....	3093kg
Dimensions L×W×H.....	3680x1675x1737mm

Note: all pressures in the manual are relative values (compared with atmospheric pressure)

Dck Yf' GrghYa

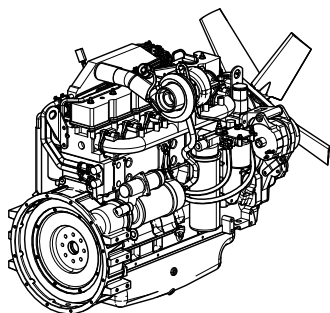

1000140875-AP1-A5

Engine Manufacturer/Brand.....	Cummins
Engine Model.....	6CTA8.3-C240
Dimensions L×W×H.....	N/A
Dry Weigh (approx.)	627Kg
Number of Cylinders.....	6
Bore.....	114mm
Stroke.....	135mm
Displacement.....	8.3L
Compression Ratio.....	N/A
Type of injection.....	Direct injection
Intake System.....	Turbocharged
Intake Resistance.....	N/A
Cooling System	Water cooled
Fan	Pusher
Battery Voltage	24V
Type of Fuel.....	No.2-ASTM D975
Type of Oil	API CD/SE or CCMCD4
Oil Capacity	18L
Type of Coolant	Glycol mixture
Coolant Capacity.....	9.8L
Back Pressure	≤76mmHg
Standby Power	N/A
Prime Power.....	178kW
Fuel Consumption(100%load).....	231g/kW.h

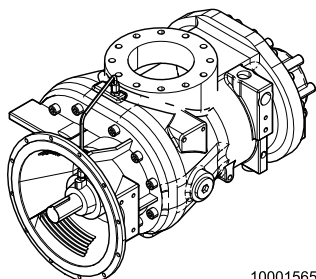

1000156533-AP1-A2

Structure.....	Oil-injection double-screw
Shaft power	135kW
Suction temperature.....	0-40°C

Working pressure	≤10.0bar
Rated speed	2200rpm
Weight	564.3kg

Control Cabinet

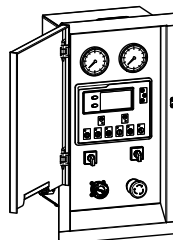

1000138882-AP1-C2

PLC of the machine is an advanced control module based on microprocessor for the automatic control and monitor system of the air compressor, realizing auto start/stop, data measure and alarm protection function. During running the module can accurately measure various parameters, like engine oil pressure, coolant temperature, discharge temperature and pressure etc. and display real values on LCD. When there is any fault, the control module alarms or stops the engine automatically and displays alarm information on LCD.

- Microprocessor control, with high stability and credibility
- Monitoring and measuring operational parameters of the air compressor
- Indicating operation status, fault conditions, all parameters and alarms
- Multiple protections; multiple parameters display, like engine oil pressure, discharge temperature and pressure etc.
- Manual and remote work mode selectable
- Real time clock for time and date display, overall runtime display
- Many configurable parameters from control panel

Warning Item	Shutdown Item
High discharge temperature	Emergency stop
High discharge pressure	Failure to start
High coolant temperature	High discharge temperature
Low engine oil pressure	High discharge pressure
Low fuel level	High coolant temperature
Low coolant level	Low engine oil pressure
Ail filter clogged	Low fuel level
Failure to stop	Low coolant level
Battery charge failure	Ail filter clogged
Low battery voltage	
High battery voltage	

4 Air and Oil Path System

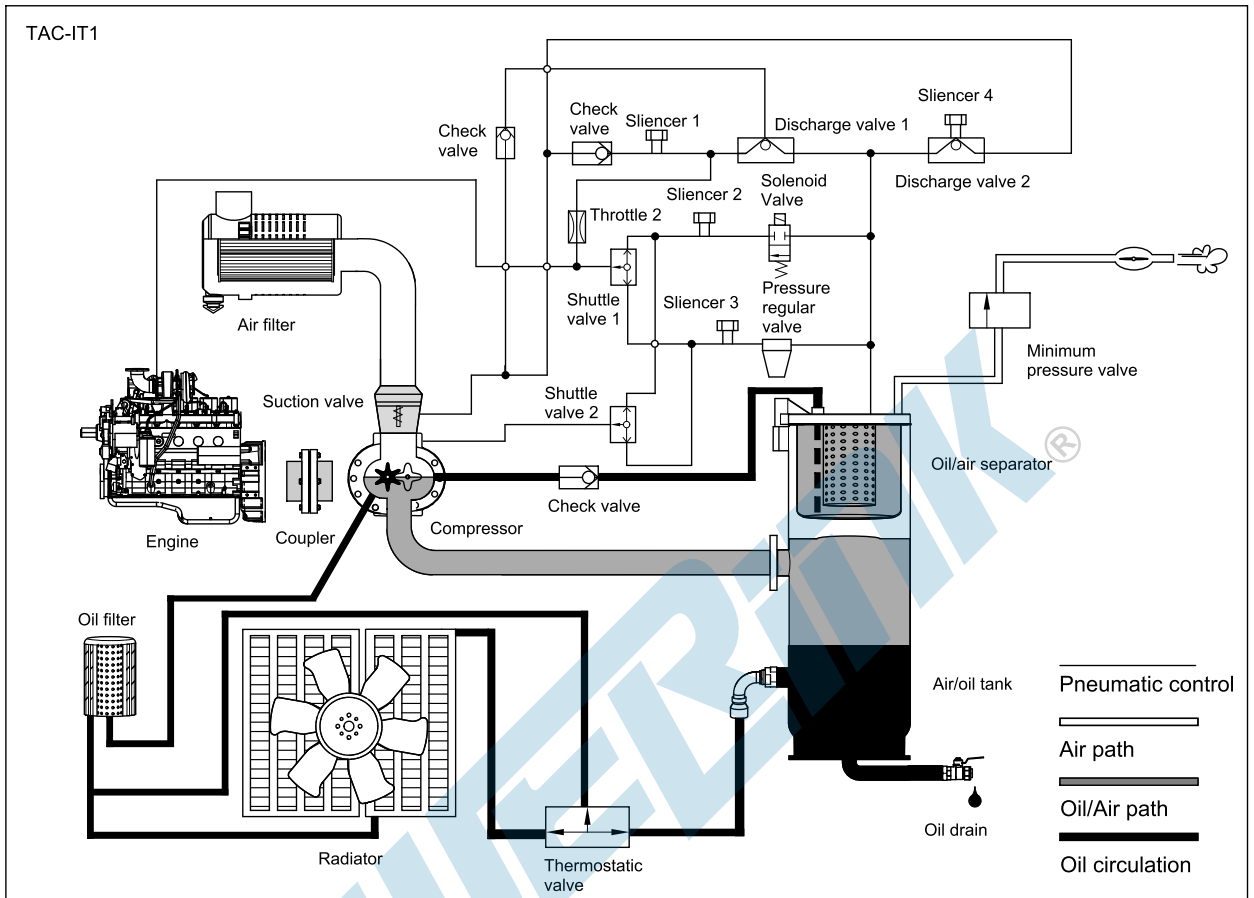

- Suction Valve
Control mode Direct proportion
Working pressure ≤ 10.0 bar
- Pressure Regular Valve
Working pressure 10.0 bar
Pressure setting mode Manual
- Minimum Pressure Valve
Activation pressure 5.0 bar
Fully opened pressure 5.0-5.5 bar
- Thermostatic Valve
Activation temperature 85°C
Fully opened temperature 100°C
- Air/oil Tank
Working pressure ≤ 10.0 bar
Activation pressure of safety valve 11.0 bar
- Air/oil Separator
Working pressure ≤ 10.0 bar
Oil residue ratio (approx.) ≤ 3 ppm

5 Control System

Control Cabinet

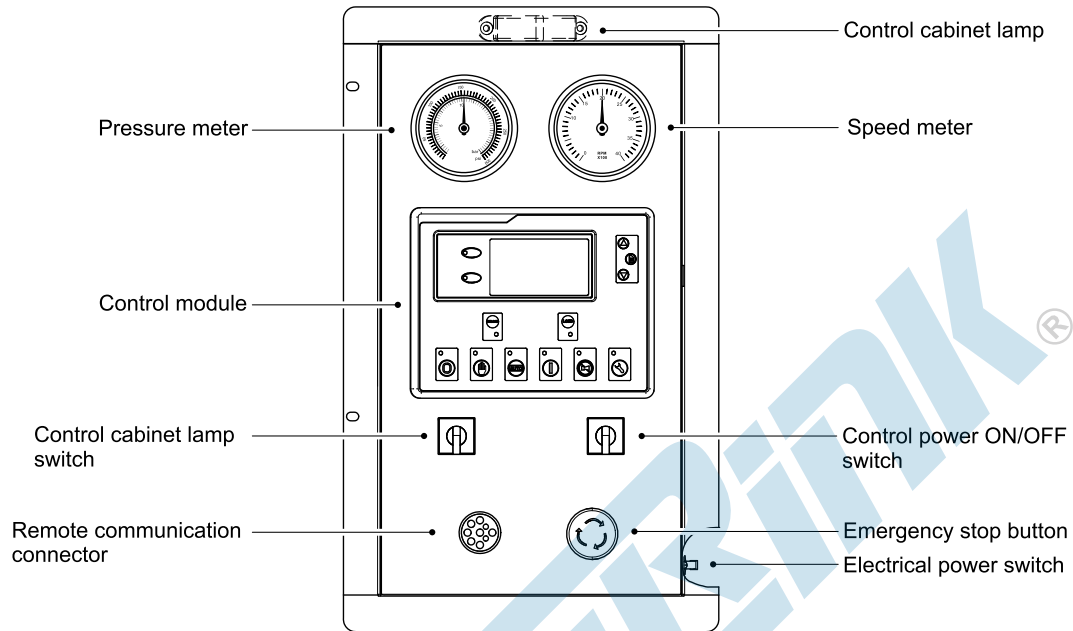

Control Module

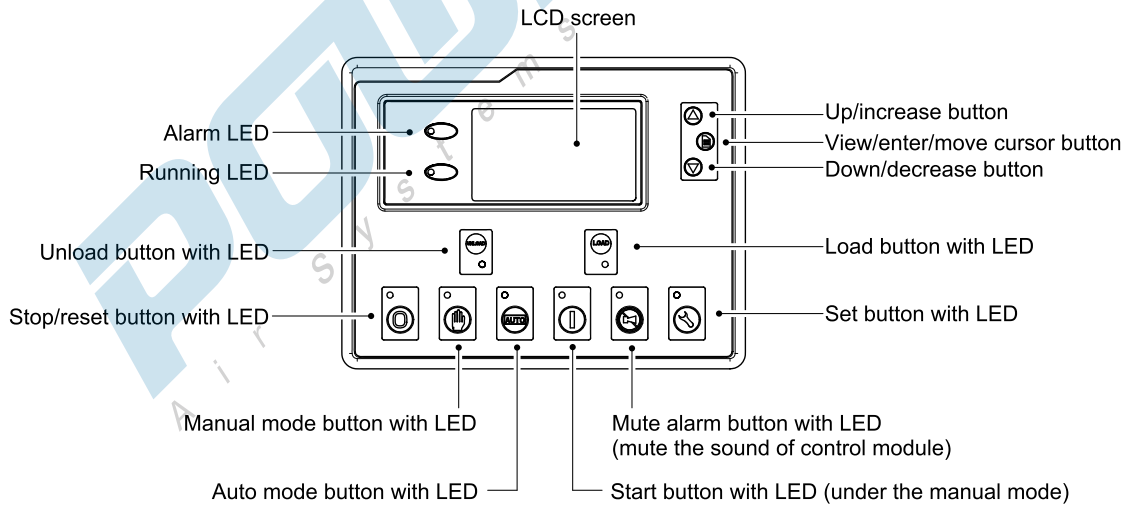

6 Overall Dimensions

3000020038-DR1-F3

Dry weight	3093kg
Dimensions	3680x1675x1737mm

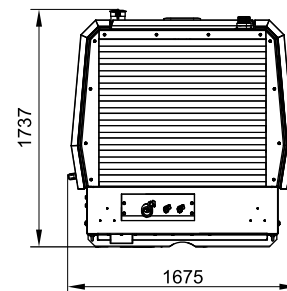
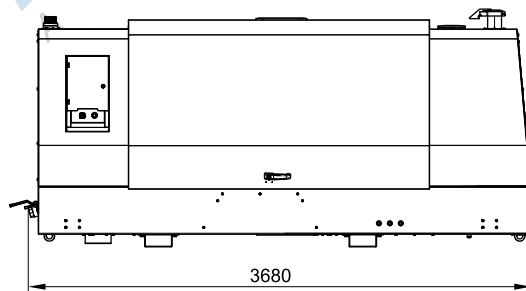
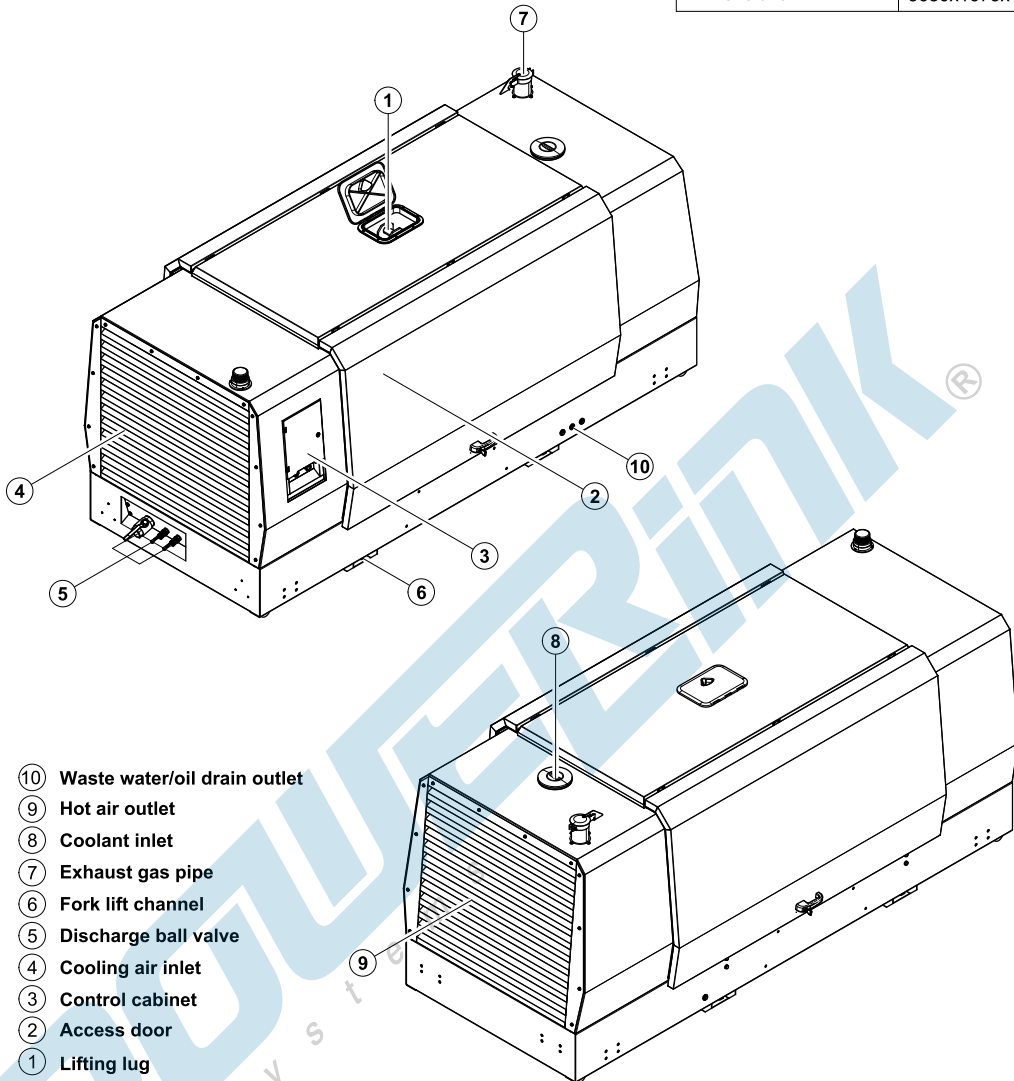

7 Optional Trailer

3000020038-DR3-F3

NON-HIGHWAY TYPE TRAILER

Dry weight of the whole	3470kg
Towing speed	≤ 20km/h
Tyre size	215/75 R17.5
Dimensions of the whole	5354x2068x2209mm

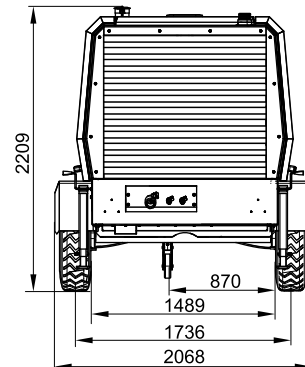
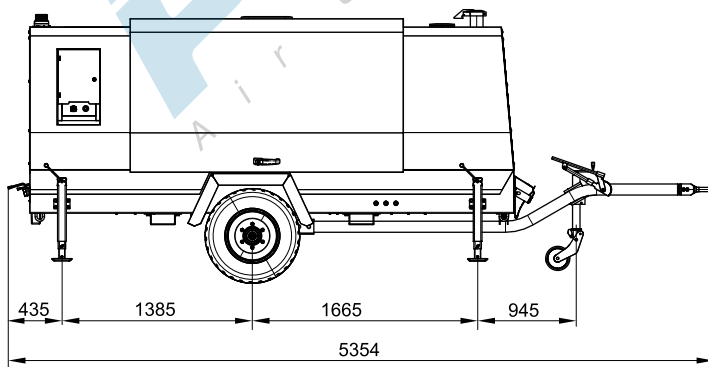
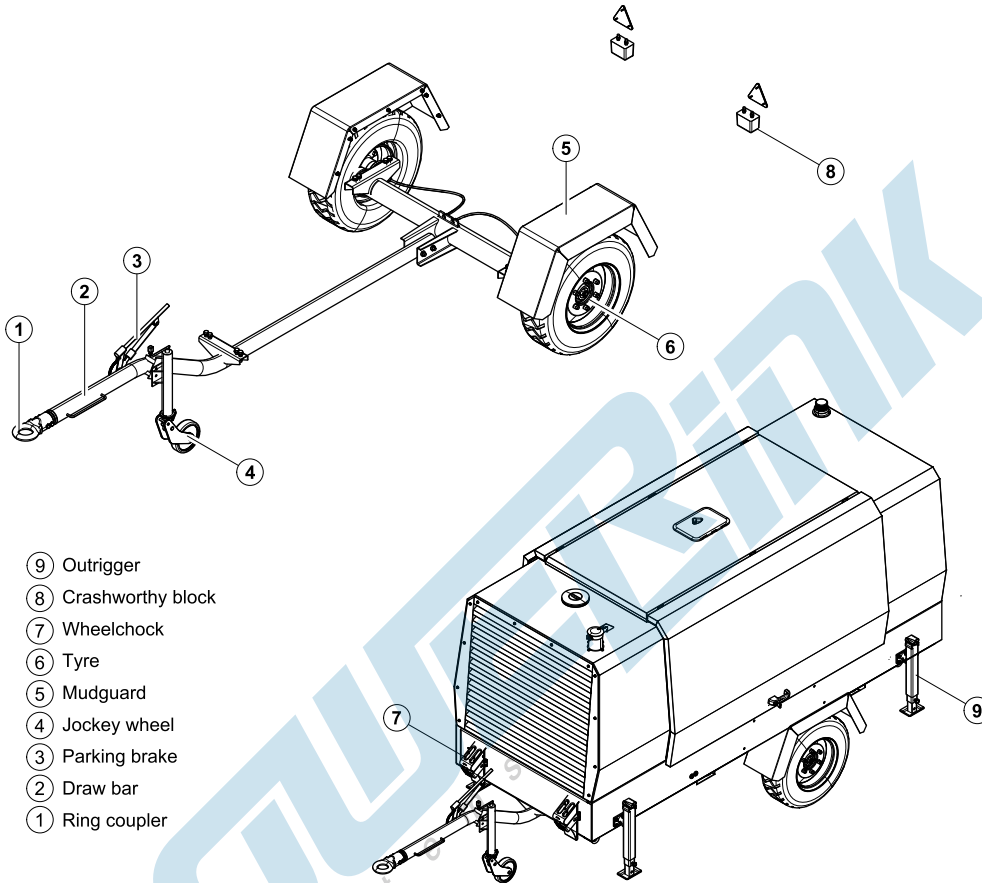

3000020038-F3-E

11.2013

POWERLINK[®]
A i r S y s t e m s

<http://www.powerlinkworld.com>

*Specification may change without prior notice. For more info.,
contact Power Link or your local distributors please.*