

**DIESEL ENGINE DRIVEN
STATIONARY AIR COMPRESSOR
DR480-13**

SPECIFICATIONS

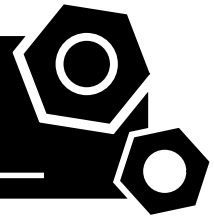

1 Standards & Conditions

Design Standards

The designs and the productions are in conformity with:

- JB/T6430-2002
- JB/T3771-1992
- JB/T4223-2007
- GB/T15487
- ISO 1217
- ISO 2151
- ASME B 19.1-1990

Environmental Operating Conditions

- Installation place: Outdoors or indoors (well ventilated).
- Ambient temperature: -25°C to 45°C. The coolant heater is needed when the temperature is below 5°C
- Humidity: Less than 80%.
- Altitude: Below one thousand (1000) meters.

Factory Inspection

- Inspection items.
- Protection devices working test.
- Starting ability in normal temperature.
- 2 hours performance test of continuous full load.
- Performance test, including flux, pressure, temperature, noise, thermal balance etc.

Painting Process

- Painting process specifications and colors are based on the manufacturer's standard.
- The customer could also choose the color which the manufacturer offers.

2 General Features

- Cummins diesel engine
- Oil-injection double-screw air compressor
- PLC controller with microprocessor technique
- Suction valve
- Solenoid valve
- Pressure regular valve
- Safety valve
- Minimum pressure valve
- Vent valve
- Shuttle valve
- Oil thermostatic valve

- 50°C radiator
- Lubricating oil radiator
- Double layer air filter of engine
- Double layer air filter of compressor
- Lubricating oil filter
- Vertical air/oil tank (ASME approval)
- Air/oil separator
- Emergency stop button
- Lockable battery isolator switch
- 2x12V/120AH sealed for life maintenance free battery
- Fuel tank for 10 hours running
- Powder coated canopy

3 Equipment Specification

Air Compressor

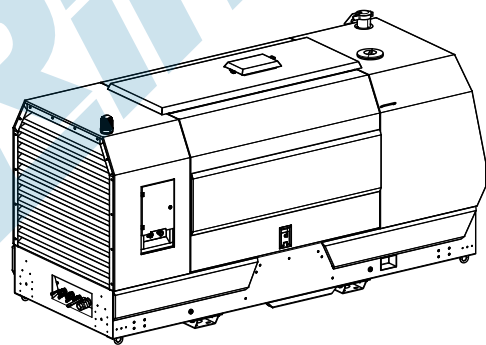

3000020035-AP1-E3

Model.....	DR480-13
Drive type	Diesel engine driven
Speed under full load.....	2200rpm
Rated flux	476cfm 13.48m ³ /min
Rated discharge pressure	13bar
Max. unloading pressure	13bar
Min. working pressure	5bar
Discharge port	3xG3/4"+1xG1 1/2"
Total capacity of oil system.....	45L
Lubricating oil type.....	Synthetic oil
Total capacity of coolant system.....	24.5L
Fuel tank capacity.....	380L
Dry weight.....	2494kg
Dimensions L×W×H.....	3705x1418x1841mm

Note: all pressures in the manual are relative values (compared with atmospheric pressure)

Diesel Engine

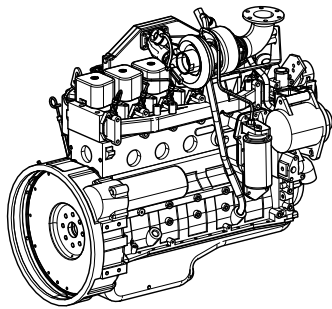

3100001801-AP1-A2

Engine Manufacturer/Brand.....	Cummins
Engine Model.....	6BTA5.9-C180
Dimensions L×W×H.....	N/A
Dry Weigh (approx.).....	453Kg
Number of Cylinders.....	6
Bore.....	102mm
Stroke.....	120mm
Displacement.....	5.9L
Compression Ratio.....	N/A
Type of injection.....	Direct injection
Intake System.....	Turbocharged
Intake Resistance.....	N/A
Cooling System.....	Water cooled
Fan.....	Pusher
Battery Voltage.....	24V
Type of Fuel.....	No.2-ASTM D975
Type of Oil.....	API CD/SE or CCMCD4
Oil Capacity.....	16.3L
Type of Coolant.....	Glycol mixture
Coolant Capacity.....	10.4L
Back Pressure.....	≤10kPa
Standby Power.....	N/A
Prime Power.....	132kW
Fuel Consumption(100%load).....	227g/kW.h

Compressor

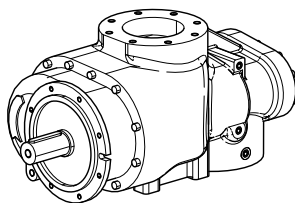

1000143601-AP1-A3

Structure.....	Oil-injection double-screw
Shaft power.....	117.6kW
Suction temperature.....	0-40°C

Working pressure.....	≤13.0bar
Rated speed.....	2200rpm
Speed ratio.....	N/A
Weight.....	350kg

Control Cabinet

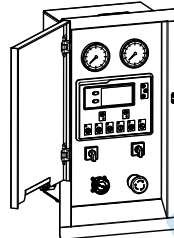

1000138882-AP1-C2

PLC of the machine is an advanced control module based on microprocessor for the automatic control and monitor system of the air compressor, realizing auto start/stop, data measure and alarm protection function. During running the module can accurately measure various parameters, like engine oil pressure, coolant temperature, discharge temperature and pressure etc. and display real values on LCD. When there is any fault, the control module alarms or stops the engine automatically and displays alarm information on LCD.

- Microprocessor control, with high stability and credibility
- Monitoring and measuring operational parameters of the air compressor
- Indicating operation status, fault conditions, all parameters and alarms
- Multiple protections; multiple parameters display, like engine oil pressure, discharge temperature and pressure etc.
- Manual and remote work mode selectable
- Real time clock for time and date display, overall runtime display
- Many configurable parameters from control panel

Warning Item	Shutdown Item
High discharge temperature	Emergency stop
High discharge pressure	Failure to start
High coolant temperature	High discharge temperature
Low engine oil pressure	High discharge pressure
Low fuel level	High coolant temperature
Low coolant level	Low engine oil pressure
Ail filter clogged	Low fuel level
Failure to stop	Low coolant level
Battery charge failure	Ail filter clogged
Low battery voltage	
High battery voltage	

4 Air and Oil Path System

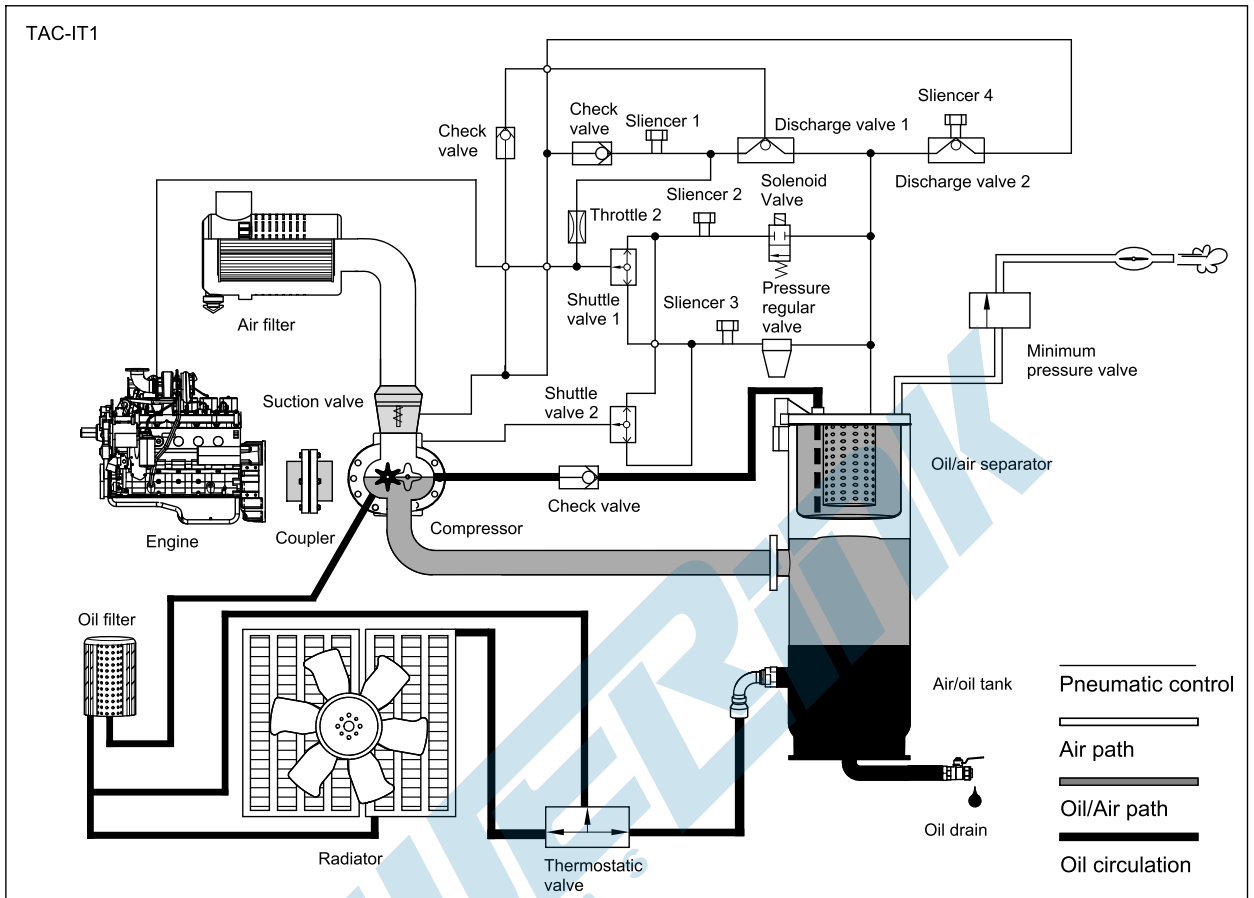

- Suction Valve
 - Control mode Direct proportion
 - Working pressure $\leq 13.0\text{bar}$
- Pressure Regular Valve
 - Working pressure 13.0bar
 - Pressure setting mode Manual
- Minimum Pressure Valve
 - Activation pressure 5.0bar
 - Fully opened pressure $5.0\text{-}5.5\text{bar}$
- Thermostatic Valve
 - Activation temperature 85°C
 - Fully opened temperature 100°C
- Air/oil Tank
 - Working pressure $\leq 13.0\text{bar}$
 - Activation pressure of safety valve 14.3bar
- Air/oil Separator
 - Working pressure $\leq 13.0\text{bar}$
 - Oil residue ratio (approx.) 3ppm

5 Control System

Control Cabinet

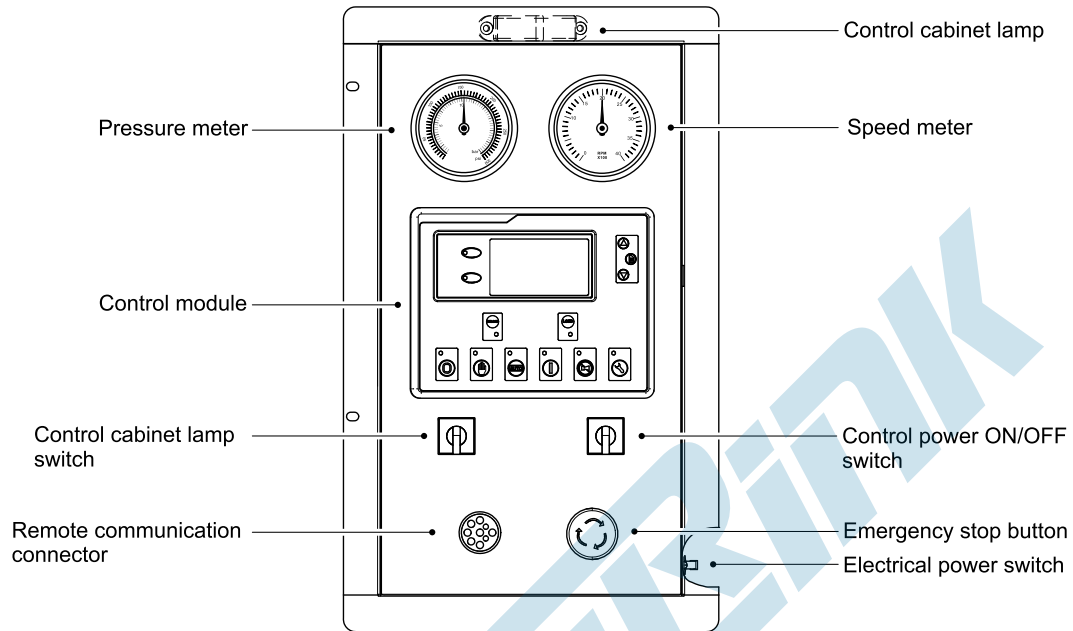

Control Module

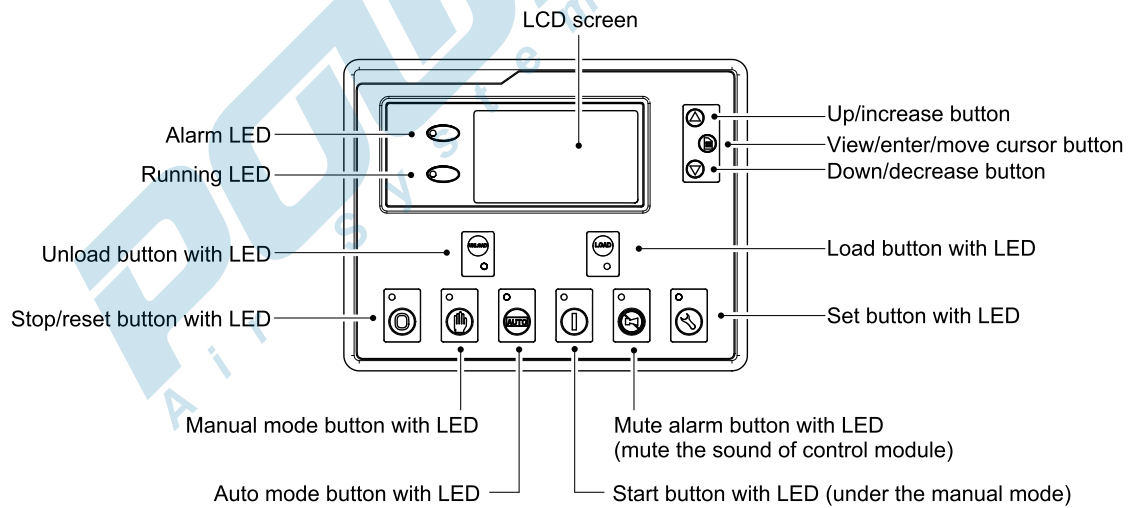

6 Overall Dimensions

3000020035-DR1-E3

Dry weight	2494kg
Dimensions	3705x1418x1841mm

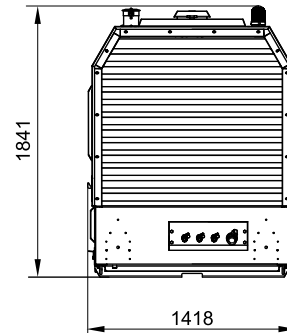
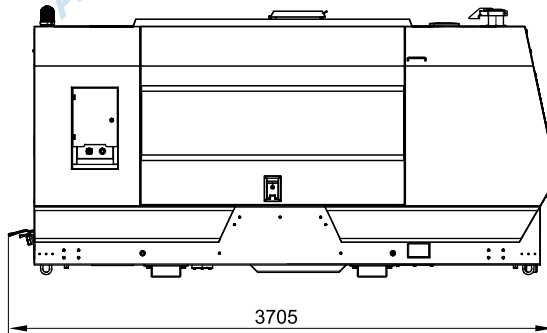
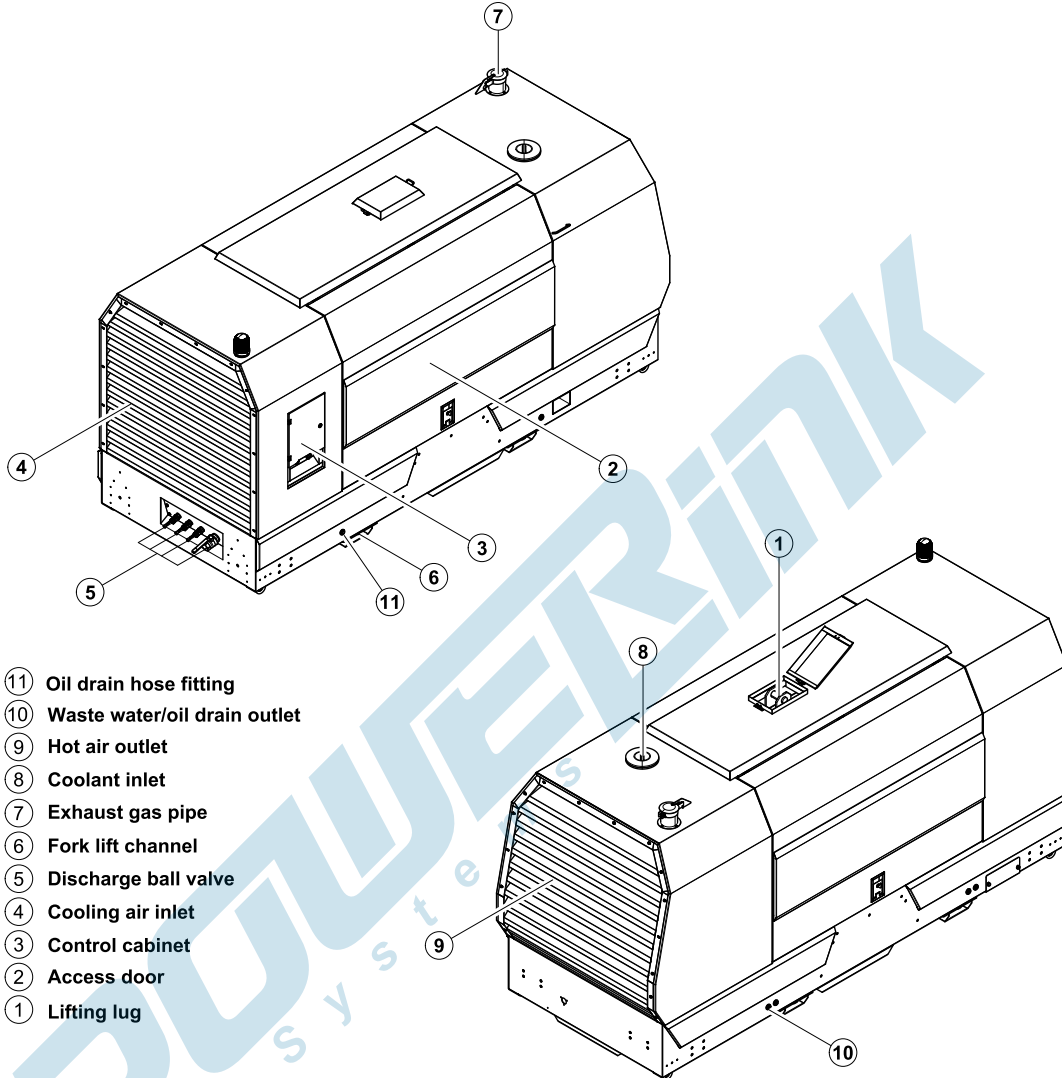

7 Optional Trailer

3000020035-DR3-E3

HIGHWAY TYPE TRAILER

Dry weight of the whole	2932kg
Towing speed	≤ 80km/h
Tyre size	7.50-16
Dimensions of the whole	5324x2028x2345mm

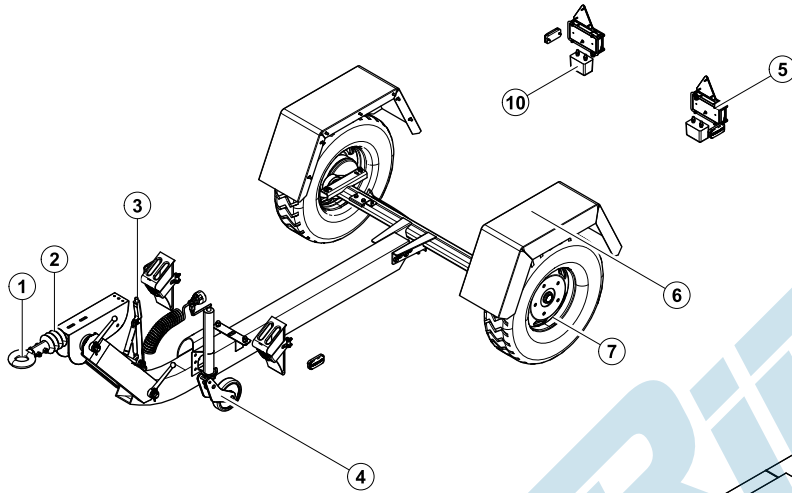

- ⑪ Outrigger
- ⑩ Crashworthy block
- ⑨ Wheelchock
- ⑧ Rear light wire
- ⑦ Tyre
- ⑥ Mudguard
- ⑤ Rear light
- ④ Jockey wheel
- ③ Parking brake
- ② Draw bar with service brake
- ① Ring coupler

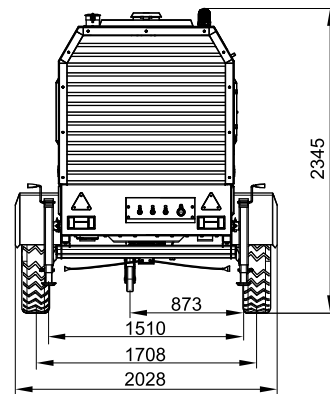
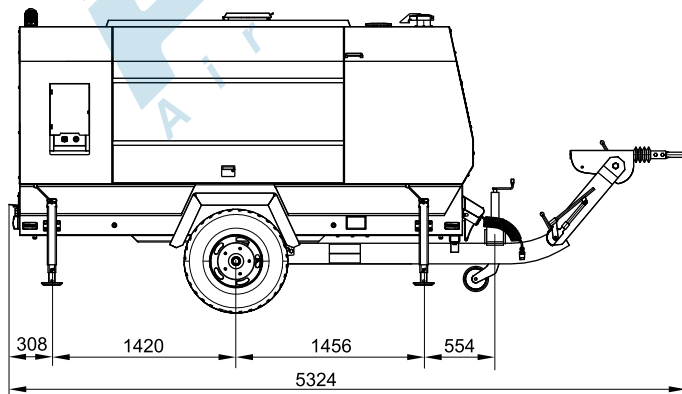
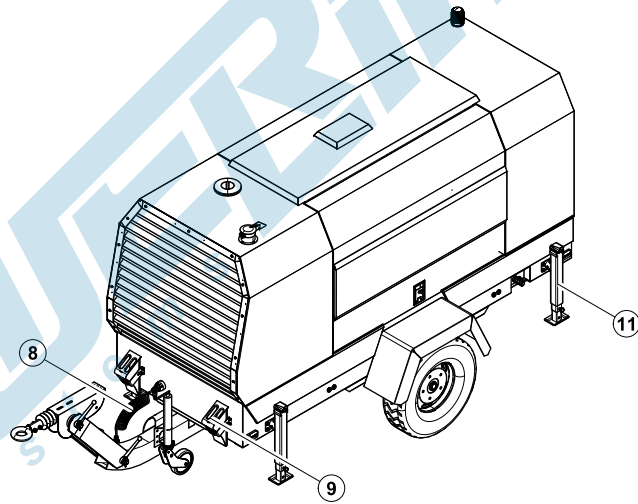

3000020035-DR5-E3

NON-HIGHWAY TYPE TRAILER

Dry weight of the whole	2792kg
Towing speed	≤ 20km/h
Tyre size	215/75 R17.5
Dimensions of the whole	5456x2028x2319mm

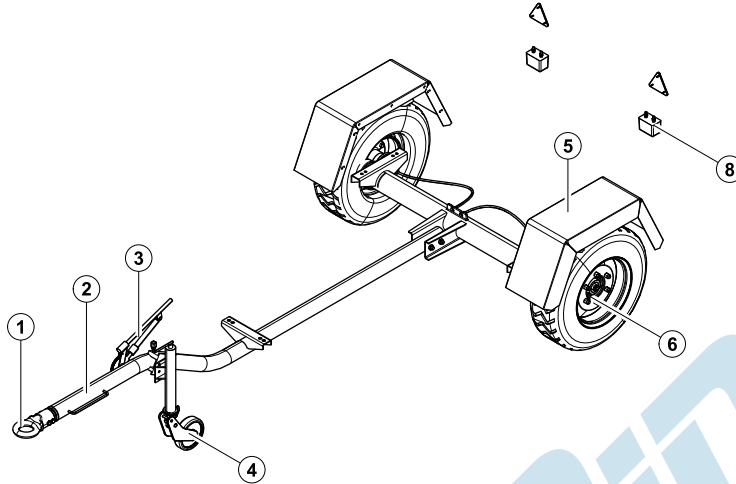

- ⑨ Outrigger
- ⑧ Crashworthy block
- ⑦ Wheelchock
- ⑥ Tyre
- ⑤ Mudguard
- ④ Jockey wheel
- ③ Parking brake
- ② Draw bar
- ① Ring coupler

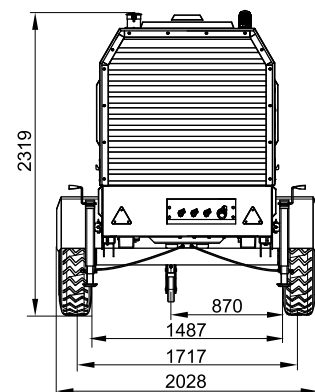
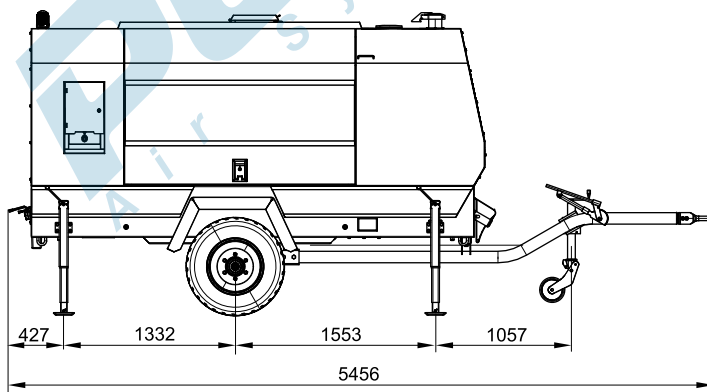
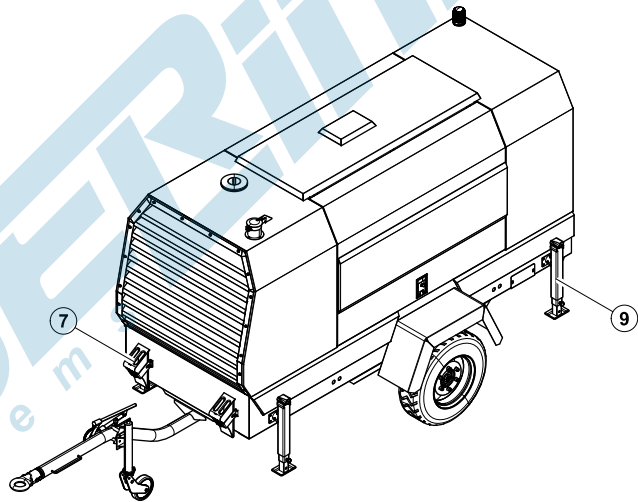

3000020035-E3-E

02.2013

POWERLINK
Air Systems

<http://www.powerlinkworld.com>

*Specification may change without prior notice. For more info.,
contact Power Link or your local distributors please.*