

**DIESEL ENGINE DRIVEN  
STATIONARY AIR COMPRESSOR  
DR400-10**

**SPECIFICATIONS**

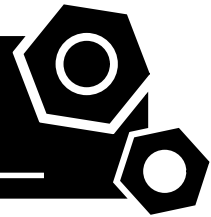

## 1 Standards & Conditions

### Design Standards

The designs and the productions are in conformity with:

- JB/T6430-2002
- JB/T3771-1992
- JB/T4223-2007
- GB/T15487
- ISO 1217
- ISO 2151
- ASME B 19.1-1990

### Environmental Operating Conditions

- Installation place: Outdoors or indoors (well ventilated).
- Ambient temperature: -25°C to 45°C. The coolant heater is needed when the temperature is below 5°C
- Humidity: Less than 80%.
- Altitude: Below one thousand (1000) meters.

### Factory Inspection

- Inspection items.
- Protection devices working test.
- Starting ability in normal temperature.
- 2 hours performance test of continuous full load.
- Performance test, including flux, pressure, temperature, noise, thermal balance etc.

### Painting Process

- Painting process specifications and colors are based on the manufacturer's standard.
- The customer could also choose the color which the manufacturer offers.

## 2 General Features

- Cummins diesel engine
- Oil-injection double-screw air compressor
- PLC controller with microprocessor technique
- Suction valve
- Solenoid valve
- Pressure regular valve
- Safety valve
- Minimum pressure valve
- Vent valve
- Shuttle valve
- Oil thermostatic valve

- 50°C radiator
- Lubricating oil radiator
- Double layer air filter of engine
- Double layer air filter of compressor
- Lubricating oil filter
- Vertical air/oil tank (ASME approval)
- Air/oil separator
- Emergency stop button
- Lockable battery isolator switch
- 2x12V/120AH sealed for life maintenance free battery
- Fuel tank for 14 hours running
- Powder coated canopy

## 3 Equipment Specification

### Air Compressor

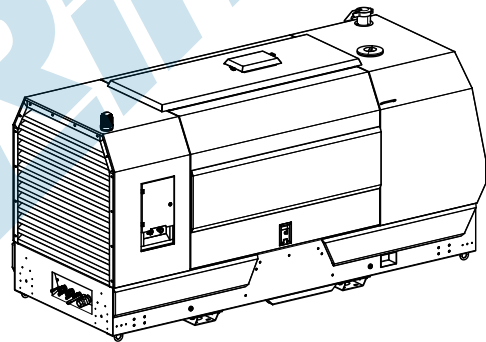

3000020030-AP1-E2

Model.....	DR400-10
Drive type .....	Diesel engine driven
Speed under full load.....	2200rpm
Rated flux .....	401cfm(11.36m <sup>3</sup> /min)
Rated discharge pressure .....	10.0bar
Max. unloading pressure .....	10.0bar
Min. working pressure .....	5.0bar
Discharge port .....	3xG3/4"+1xG1 1/2"
Total capacity of oil system.....	45L
Lubricating oil type.....	Synthetic oil
Total capacity of coolant system.....	24.5L
Fuel tank capacity.....	380L
Dry weight.....	2506kg
Dimensions L×W×H.....	3705x1418x1841mm

Note: all pressures in the manual are relative values (compared with atmospheric pressure)

## Diesel Engine

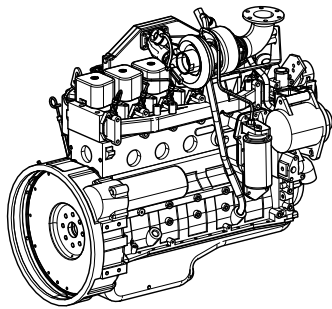

3100001801-AP1-A2

Engine Manufacturer/Brand.....	Cummins
Engine Model.....	6BTA5.9-C180
Dimensions L×W×H.....	N/A
Dry Weigh (approx.).....	453Kg
Number of Cylinders.....	6
Bore.....	102mm
Stroke.....	120mm
Displacement.....	5.9L
Compression Ratio.....	N/A
Type of injection.....	Direct injection
Intake System.....	Turbocharged
Intake Resistance.....	N/A
Cooling System.....	Water cooled
Fan.....	Pusher
Battery Voltage.....	24V
Type of Fuel.....	No.2-ASTM D975
Type of Oil.....	API CD/SE or CCMCD4
Oil Capacity.....	16.3L
Type of Coolant.....	Glycol mixture
Coolant Capacity.....	10.4L
Back Pressure.....	≤10kPa
Standby Power.....	N/A
Prime Power.....	132kW
Fuel Consumption(100%load).....	227g/kW.h

## Compressor

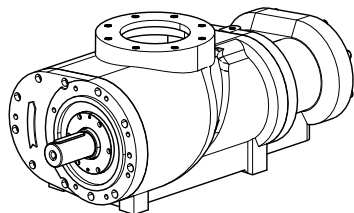

3100001885-AP1-A6

Structure.....	Oil-injection double-screw
Shaft power.....	87kW
Suction temperature.....	0-40°C

Working pressure.....	≤10.0bar
Rated speed.....	2200rpm
Speed ratio.....	N/A
Weight.....	330kg

## Control Cabinet

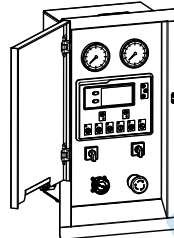

1000138882-AP1-B4

PLC of the machine is an advanced control module based on microprocessor for the automatic control and monitor system of the air compressor, realizing auto start/stop, data measure and alarm protection function. During running the module can accurately measure various parameters, like engine oil pressure, coolant temperature, discharge temperature and pressure etc. and display real values on LCD. When there is any fault, the control module alarms or stops the engine automatically and displays alarm information on LCD.

- Microprocessor control, with high stability and credibility
- Monitoring and measuring operational parameters of the air compressor
- Indicating operation status, fault conditions, all parameters and alarms
- Multiple protections; multiple parameters display, like engine oil pressure, discharge temperature and pressure etc.
- Manual and remote work mode selectable
- Real time clock for time and date display, overall runtime display
- Many configurable parameters from control panel

Warning Item	Shutdown Item
High discharge temperature	Emergency stop
High discharge pressure	Failure to start
High coolant temperature	High discharge temperature
Low engine oil pressure	High discharge pressure
Low fuel level	High coolant temperature
Low coolant level	Low engine oil pressure
Ail filter clogged	Low fuel level
Failure to stop	Low coolant level
Battery charge failure	Ail filter clogged
Low battery voltage	
High battery voltage	

## 4 Air and Oil Path System

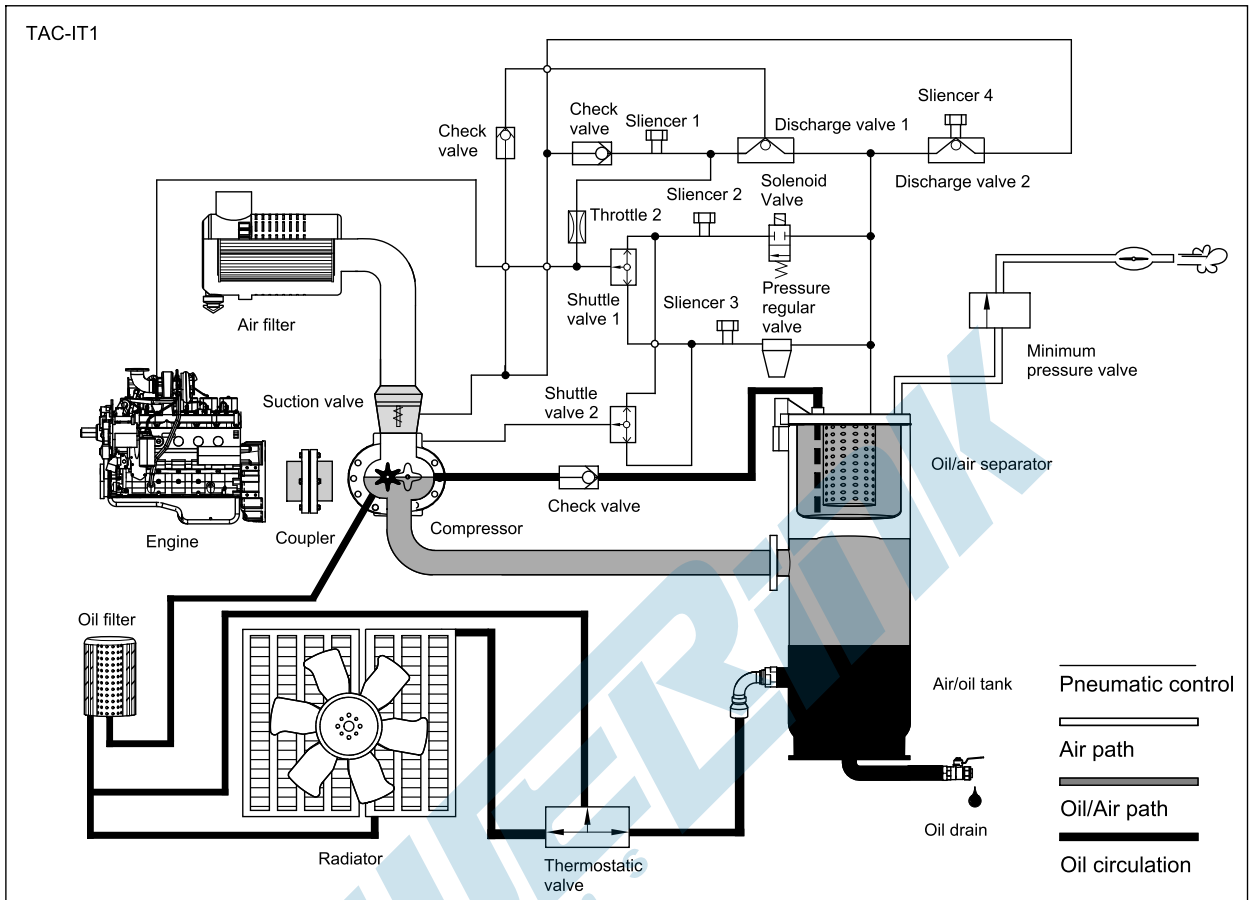

- Suction Valve  
Control mode ..... Direct proportion  
Working pressure .....  $\leq 10.0$  bar
- Pressure Regular Valve  
Working pressure ..... 10.0 bar  
Pressure setting mode ..... Manual
- Minimum Pressure Valve  
Activation pressure ..... 5.0 bar  
Fully opened pressure ..... 5.0-5.5 bar
- Thermostatic Valve  
Activation temperature ..... 85°C  
Fully opened temperature ..... 100°C
- Air/oil Tank  
Working pressure .....  $\leq 10.0$  bar  
Activation pressure of safety valve ..... 11.0 bar
- Air/oil Separator  
Working pressure .....  $\leq 10.0$  bar  
Oil residue ratio (approx.) .....  $\leq 3$  ppm

## 5 Control System

### Control Cabinet

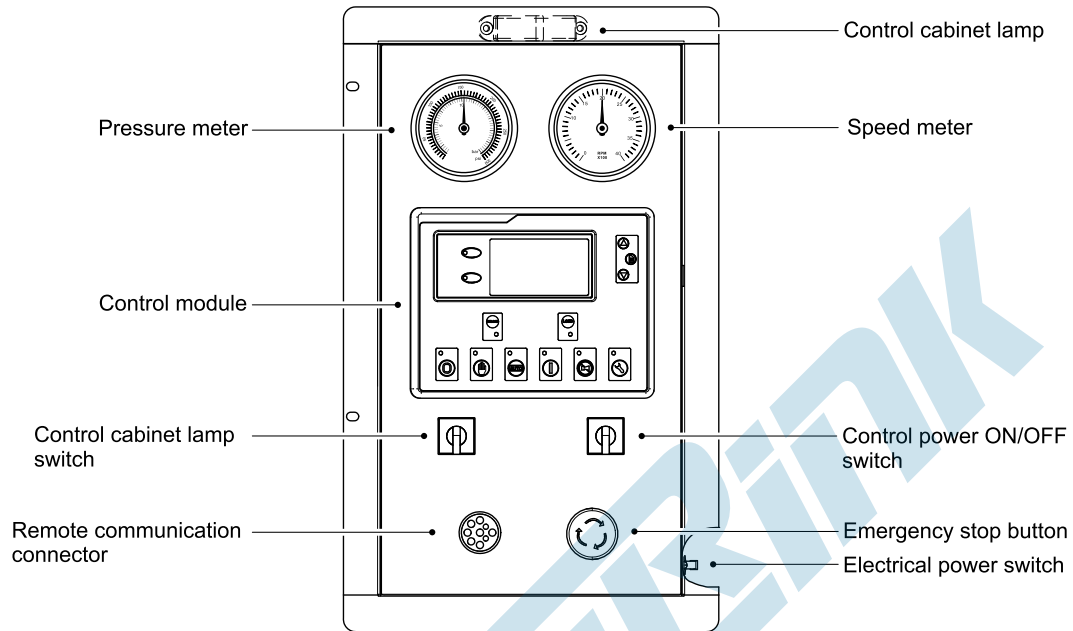

### Control Module

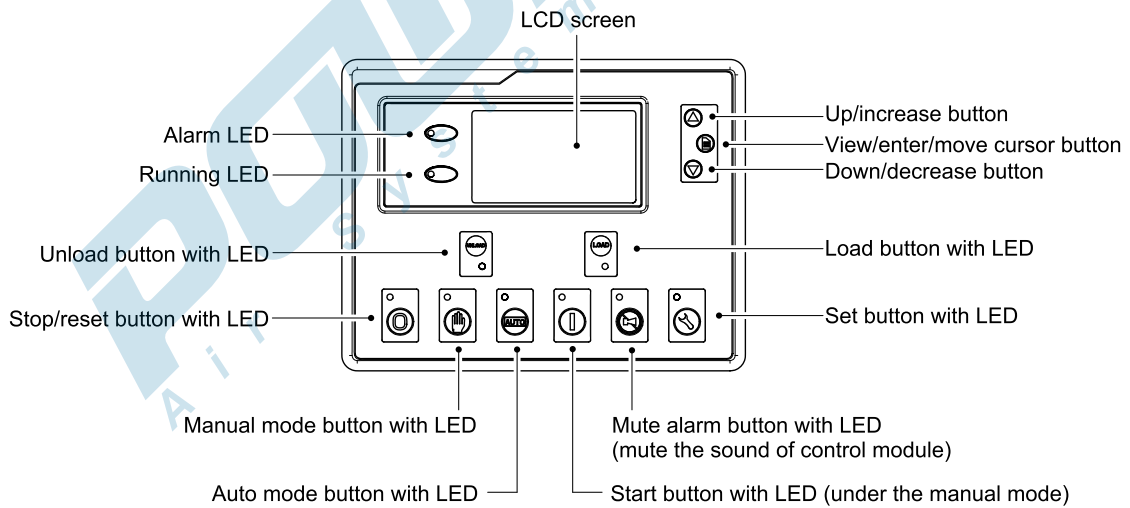

## 6 Overall Dimensions

3000020030-DR1-E2

Dry weight	2506kg
Dimensions	3705x1418x1841mm

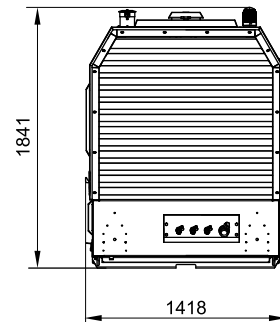
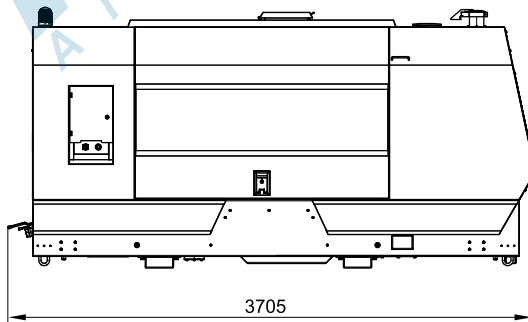
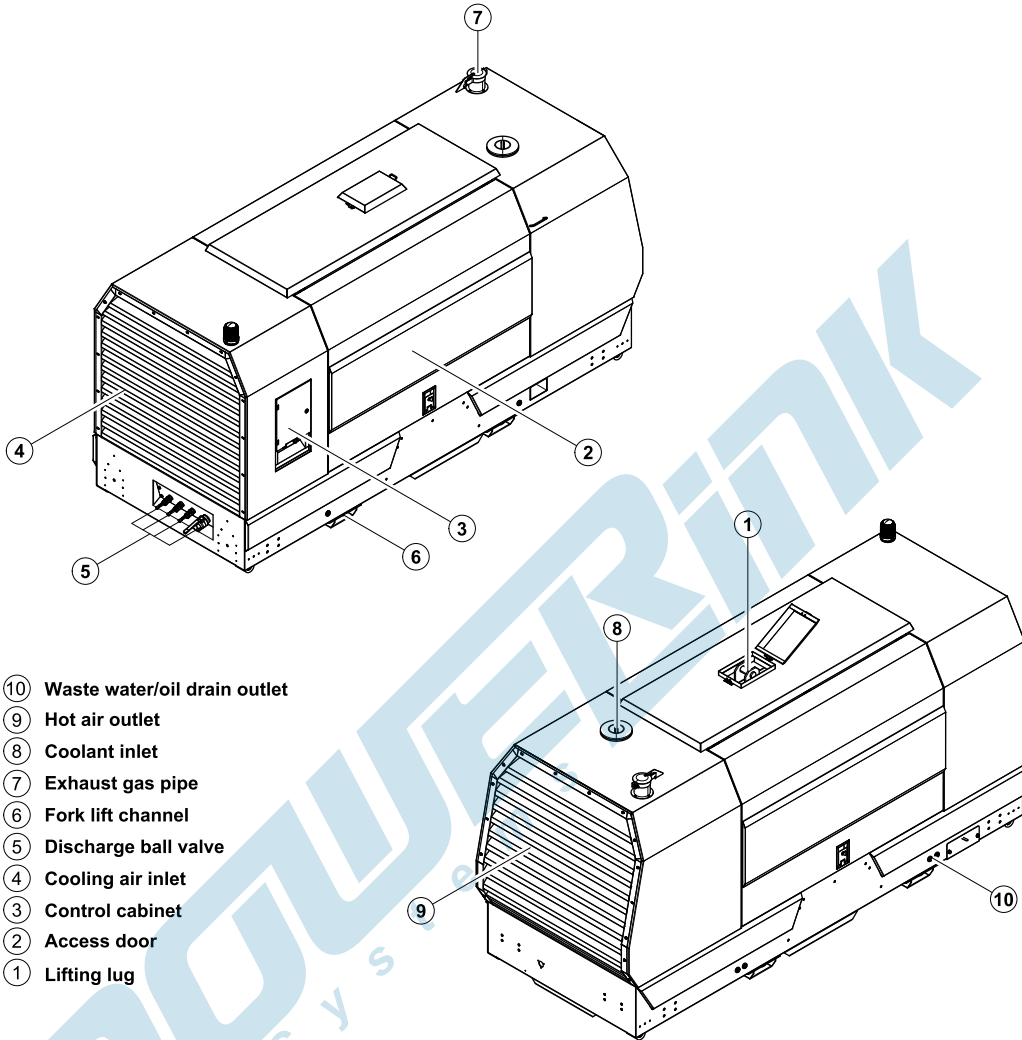

## 7 Optional Trailer

3000020030-DR3-E2

### HIGHWAY TYPE TRAILER

Dry weight of the whole	2993kg
Towing speed	≤ 80km/h
Tyre size	7.50-16
Dimensions of the whole	5324x2028x2345mm

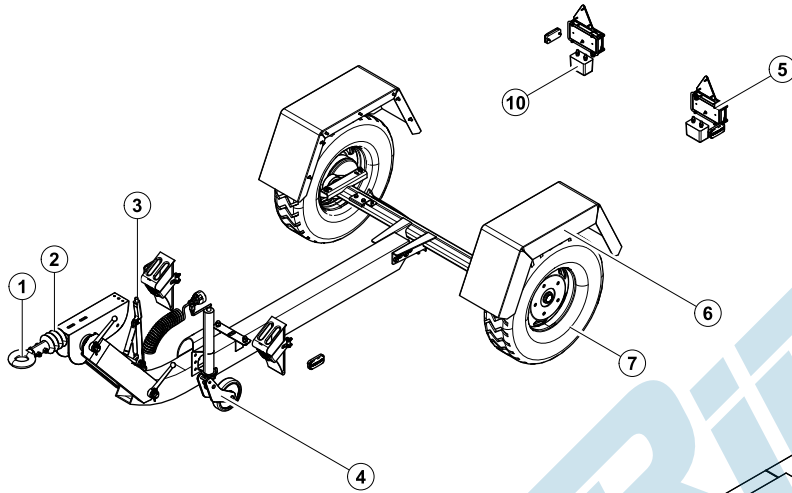

- ⑪ Outrigger
- ⑩ Crashworthy block
- ⑨ Wheelchock
- ⑧ Rear light wire
- ⑦ Tyre
- ⑥ Mudguard
- ⑤ Rear light
- ④ Jockey wheel
- ③ Parking brake
- ② Draw bar with service brake
- ① Ring coupler

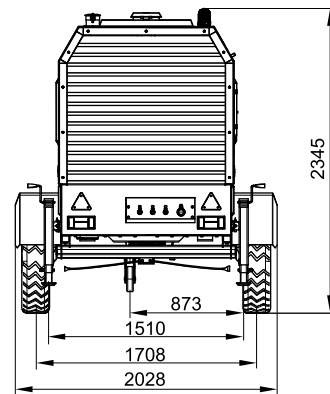
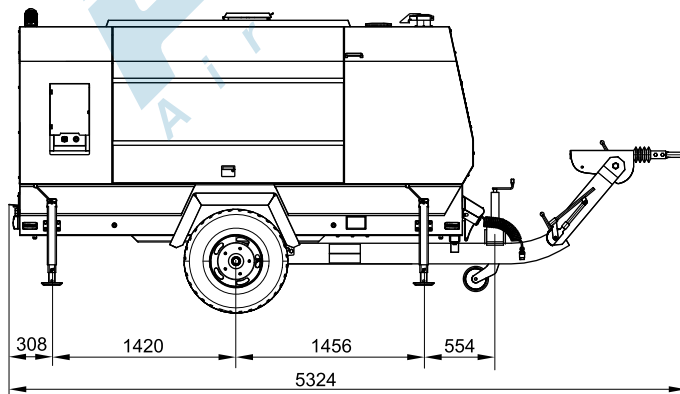
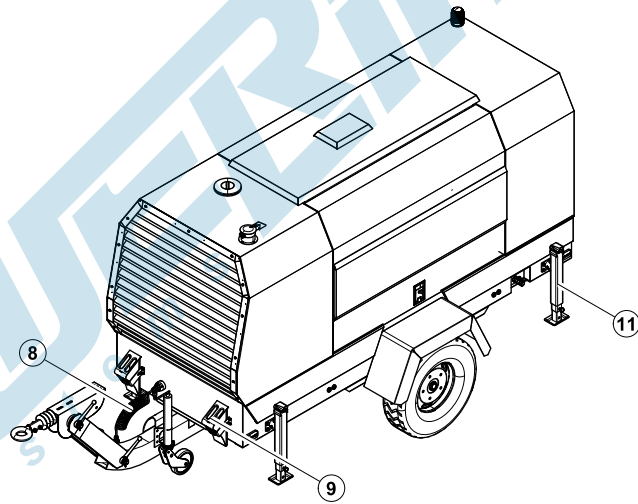

3000020030-DR5-E2

**NON-HIGHWAY TYPE TRAILER**

Dry weight of the whole	2803kg
Towing speed	≤ 20km/h
Tyre size	215/75 R17.5
Dimensions of the whole	5456x2028x2319mm

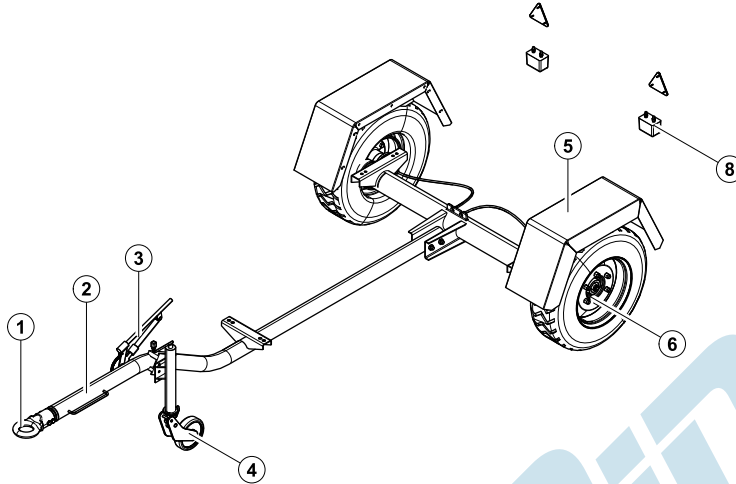

- ⑨ Outrigger
- ⑧ Crashworthy block
- ⑦ Wheelchock
- ⑥ Tyre
- ⑤ Mudguard
- ④ Jockey wheel
- ③ Parking brake
- ② Draw bar
- ① Ring coupler

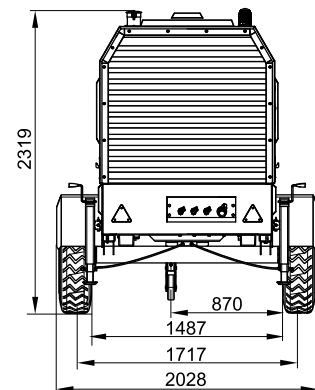
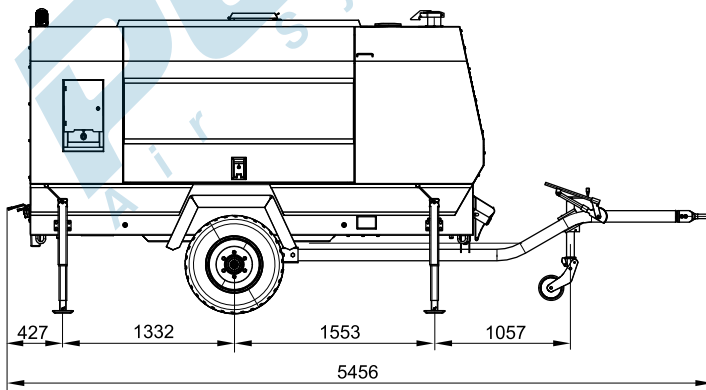
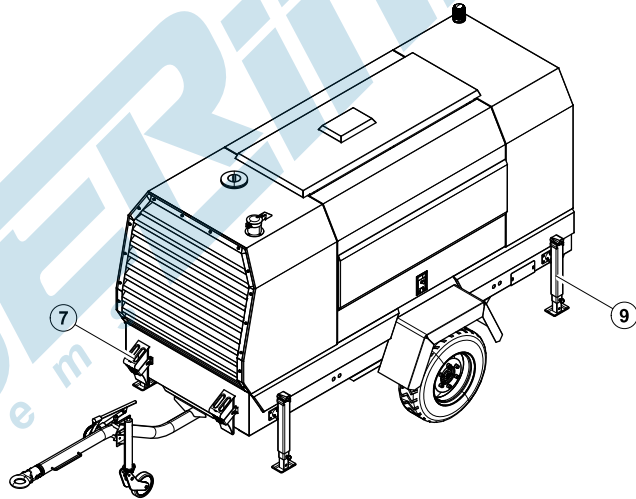

3000020030-E2-E
12.2012

**POWERLINK**  
Air Systems

<http://www.powerlinkworld.com>

*Specification may change without prior notice. For more info.,  
contact Power Link or your local distributors please.*