

**DIESEL ENGINE DRIVEN
STATIONARY AIR COMPRESSOR
DR300-10**

SPECIFICATIONS

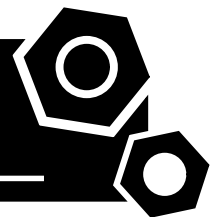

1 Standards & Conditions

Design Standards

The designs and the productions are in conformity with:

- JB/T6430-2002
- JB/T3771-1992
- JB/T4223-2007
- GB/T15487
- ISO 1217
- ISO 2151
- ASME B 19.1-1990

Environmental Operating Conditions

- Installation place: Outdoors or indoors (well ventilated).
- Ambient temperature: -25°C to 45°C. The coolant heater is needed when the temperature is below 5°C
- Humidity: Less than 80%.
- Altitude: Below one thousand (1000) meters.

Factory Inspection

- Inspection items.
- Protection devices working test.
- Starting ability in normal temperature.
- 2 hours performance test of continuous full load.
- Performance test, including flux, pressure, temperature, noise, thermal balance etc.

Painting Process

- Painting process specifications and colors are based on the manufacturer's standard.
- The customer could also choose the color which the manufacturer offers.

2 General Features

- Cummins diesel engine
- Oil-injection double-screw air compressor
- PLC controller with microprocessor technique
- Suction valve
- Solenoid valve
- Pressure regular valve
- Safety valve
- Minimum pressure valve
- Vent valve

- Shuttle valve
- Oil thermostatic valve
- 50°C radiator
- Lubricating oil radiator
- Double layer air filter
- Lubricating oil filter
- Vertical air/oil tank (ASME approval)
- Air/oil separator
- Emergency stop button
- Lockable battery isolator switch
- 1x12V/120AH sealed for life maintenance free battery
- Fuel tank for 8 hours running
- Powder coated canopy

3 Equipment Specification

Air Compressor

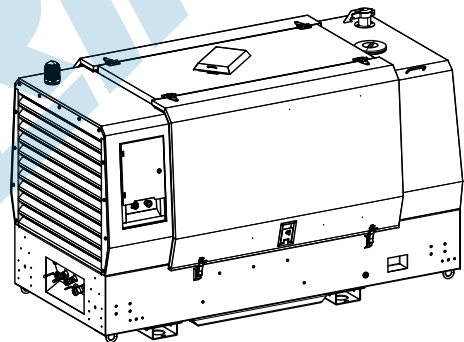

3000020021-AP1-A6

Model.....	DR300-10
Drive type	Diesel engine driven
Speed under full load.....	2200rpm
Rated flux	304cfm(8.61m ³ /min)
Rated discharge pressure	10.0bar
Discharge port	2xG3/4"+1xG1"
Total capacity of oil system.....	35L
Lubricating oil type.....	Synthetic oil
Total capacity of coolant system.....	20L
Fuel tank capacity.....	170L
Dry weight.....	1785.4kg
Dimensions L×W×H.....	2642x1356x1601mm

Note: all pressures in the manual are relative values (compared with atmospheric pressure)

Diesel Engine

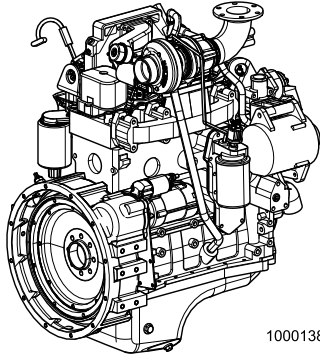

1000138190-AP1-A8

Engine Manufacturer/Brand.....	Cummins
Engine Model.....	4BTA3.9-C125
Dimensions L×W×H.....	845x847x988mm
Dry Weigh (approx.).....	355Kg
Number of Cylinders.....	4
Bore.....	102mm
Stroke.....	120mm
Displacement.....	3.9L
Compression Ratio.....	N/A
Type of injection.....	Direct injection
Intake System.....	Turbocharged,Air to water charge cooled
Intake Resistance.....	≤6.2kPa
Cooling System.....	Water cooled
Fan.....	Pusher
Battery Voltage.....	12/24V
Type of Fuel.....	No.2-ASTM D975
Type of Oil.....	API CD/SE or CCMCD4
Oil Capacity.....	9.0L
Type of Coolant.....	Glycol mixture
Coolant Capacity.....	8.3L
Back Pressure.....	≤10kPa
Standby Power.....	N/A
Prime Power.....	93kW
Fuel Consumption(100%load).....	22.5L/H

Compressor

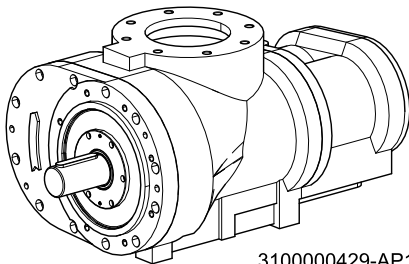

3100000429-AP1-A4

Structure.....	Oil-injection double-screw
Axis power.....	66.0kW
Suction temperature.....	0-40°C

Working pressure.....	≤10.0bar
Rated speed.....	2200rpm
Speed ratio.....	N/A
Weight.....	280kg

Control Cabinet

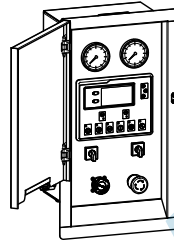

1000138882-AP1-B4

PLC of the machine is an advanced control module based on microprocessor for the automatic control and monitor system of the air compressor, realizing auto start/stop, data measure and alarm protection function. During running the module can accurately measure various parameters, like engine oil pressure, coolant temperature, discharge temperature and pressure etc. and display real values on LCD. When there is any fault, the control module alarms or stops the engine automatically and displays alarm information on LCD.

- Microprocessor control, with high stability and credibility
- Monitoring and measuring operational parameters of the air compressor
- Indicating operation status, fault conditions, all parameters and alarms
- Multiple protections; multiple parameters display, like engine oil pressure, discharge temperature and pressure etc.
- Manual and remote work mode selectable
- Real time clock for time and date display, overall runtime display
- Many configurable parameters from control panel

Warning Item	Shutdown Item
High discharge temperature	Emergency stop
High discharge pressure	Failure to start
High coolant temperature	High discharge temperature
Low engine oil pressure	High discharge pressure
Low fuel level	High coolant temperature
Low coolant level	Low engine oil pressure
Ail filter clogged	Low fuel level
Failure to stop	Low coolant level
Battery charge failure	Ail filter clogged
Low battery voltage	
High battery voltage	

4 Air and Oil Path System

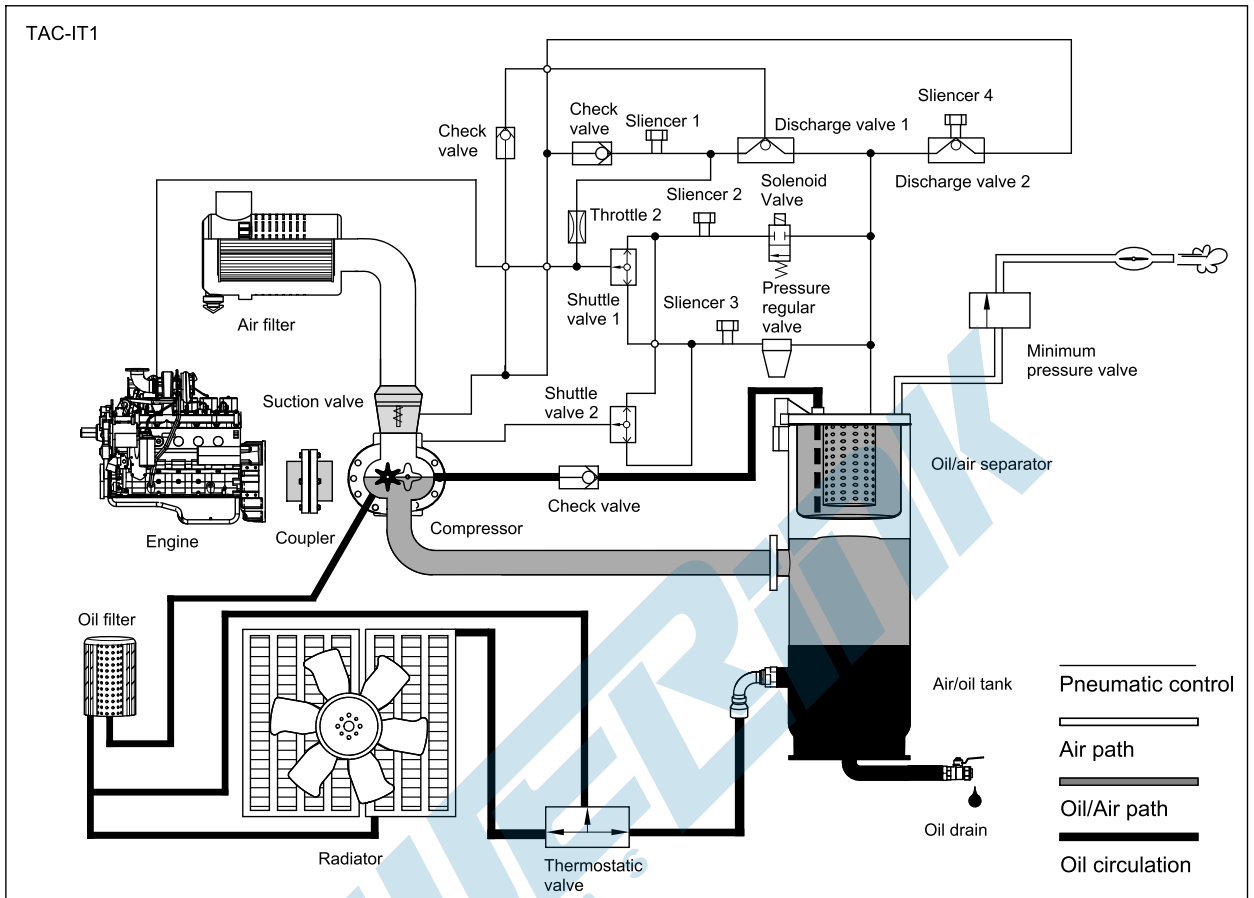

- Suction Valve
Control mode Direct proportion
Working pressure ≤ 10.0 bar
- Pressure Regular Valve
Working pressure 10.0bar
Pressure setting mode Manual
- Minimum Pressure Valve
Activation pressure 5.0bar
Fully opened pressure 5.0-5.5bar
- Thermostatic Valve
Activation temperature 85°C
Fully opened temperature 100°C
- Air/oil Tank
Working pressure ≤ 10.0 bar
Activation pressure of safety valve 11.0bar
- Air/oil Separator
Working pressure ≤ 10.0 bar
Oil residue ratio (approx.) ≤ 3 ppm

5 Control System

Control Cabinet

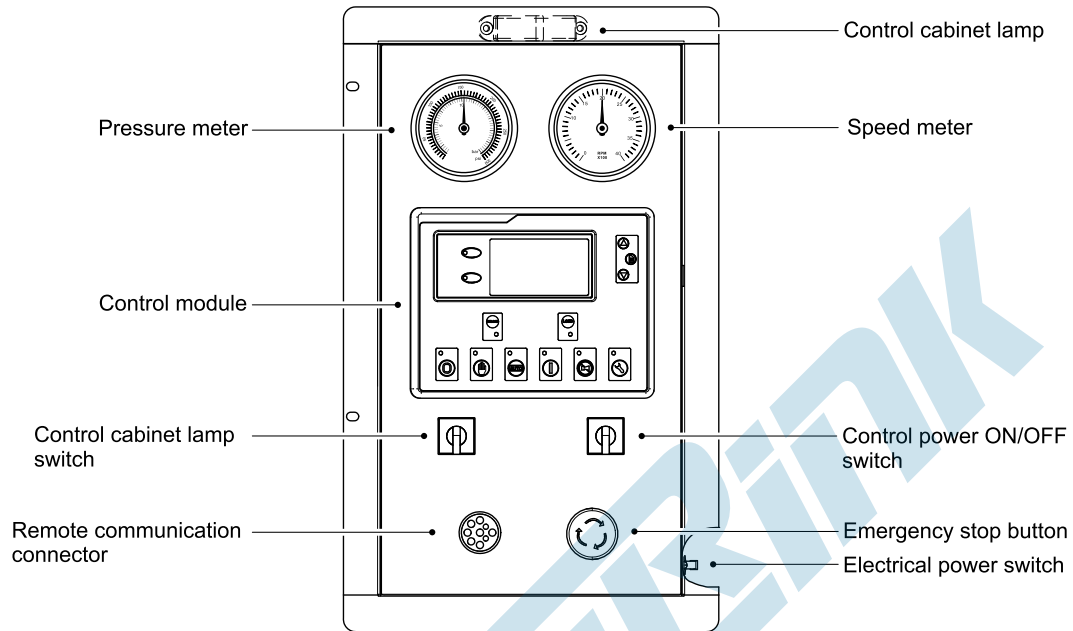

Control Module

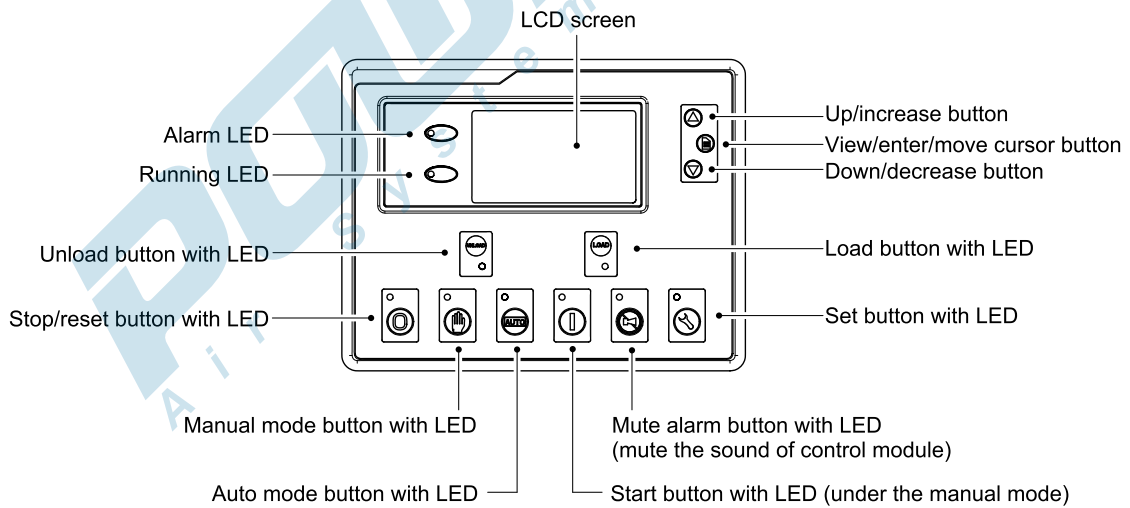

6 Overall Dimensions

3000020021-DR1-A6

Dry weight	1785.4kg
Dimensions	2642x1356x1601mm

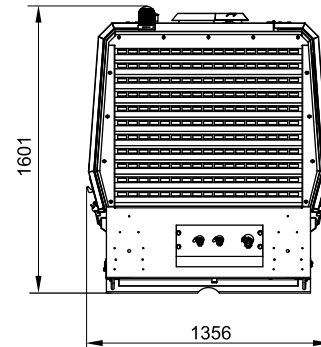
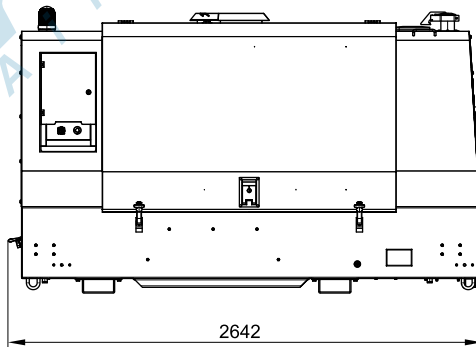
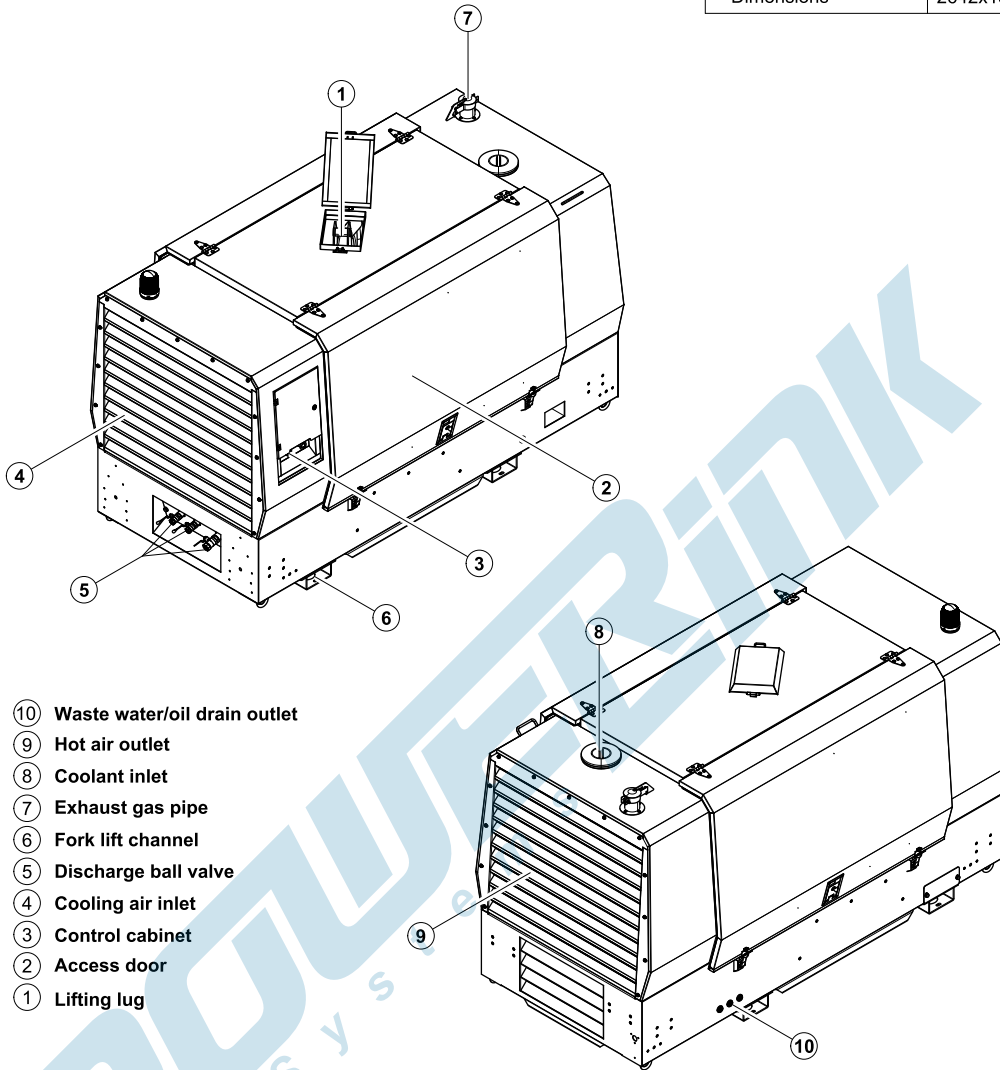

7 Optional Trailer

3000020021-DR3-A6

HIGHWAY TYPE TRAILER

Dry weight of the whole	2358kg
Towing speed	≤ 80km/h
Tyre size	195R14
Dimensions of the whole	4567x1660x2054mm

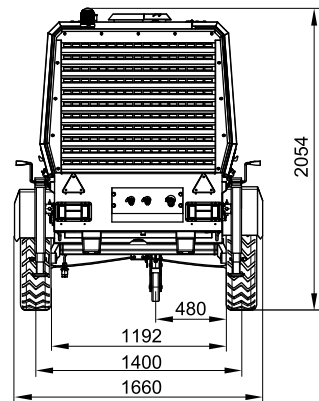
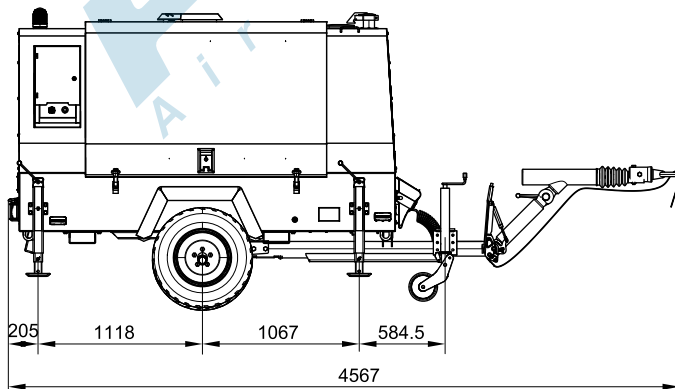
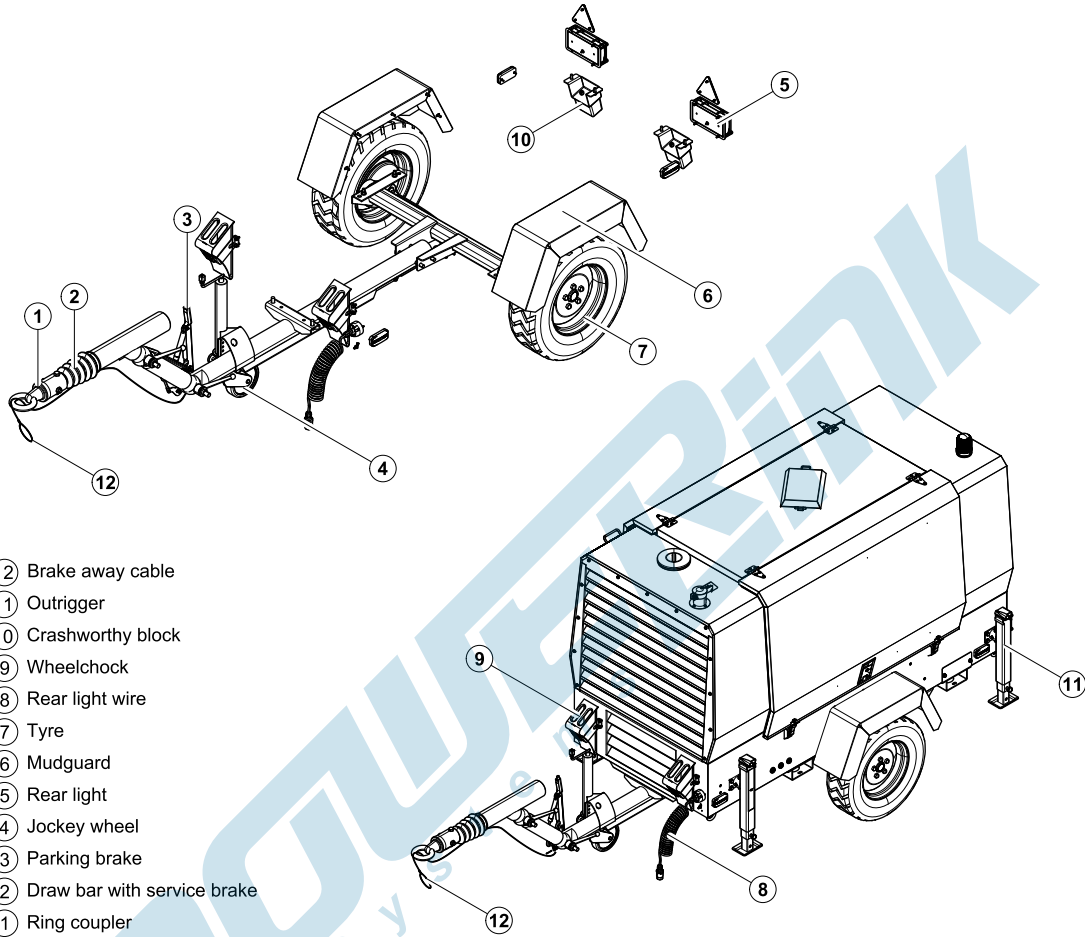

300020021-DR5-A6

NON-HIGHWAY TYPE TRAILER

Dry weight of the whole	2085kg
Towing speed	≤ 20km/h
Tyre size	215/75 R17.5
Dimensions of the whole	4192x1768x2123mm

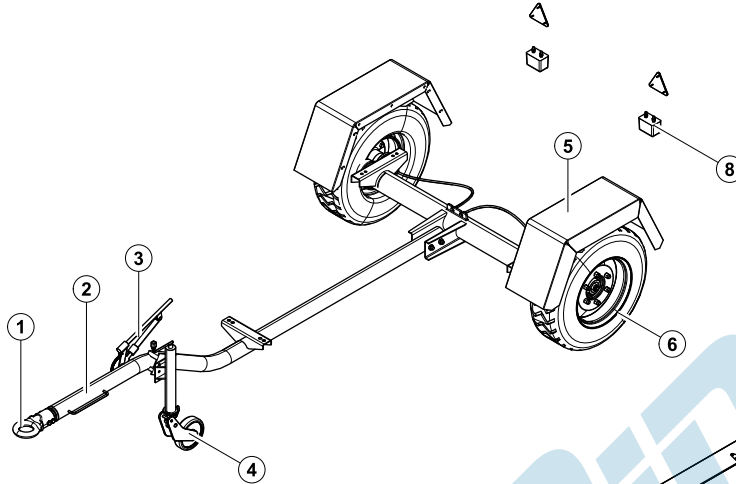

- ⑨ Outrigger
- ⑧ Crashworthy block
- ⑦ Wheelchock
- ⑥ Tyre
- ⑤ Mudguard
- ④ Jockey wheel
- ③ Parking brake
- ② Draw bar
- ① Ring coupler

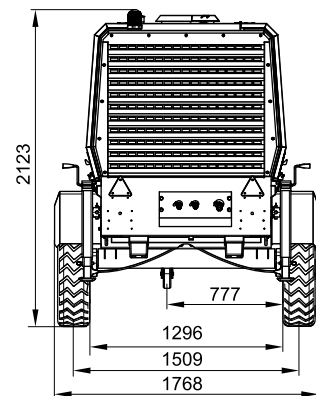
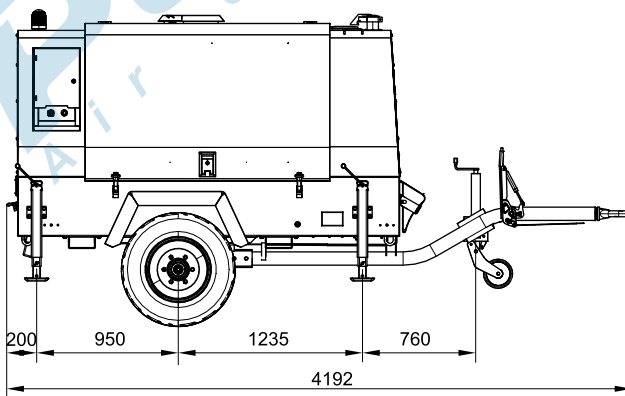
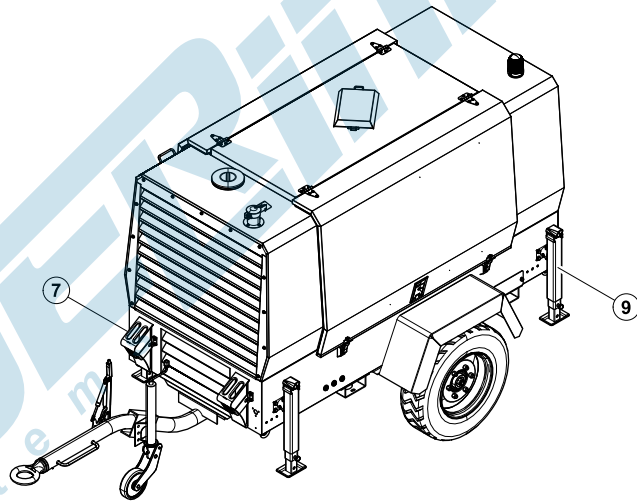

3000020021-A6-E

08.2012

POWERLINK
Air Systems

<http://www.powerlinkworld.com>

*Specification may change without prior notice. For more info.,
contact Power Link or your local distributors please.*